

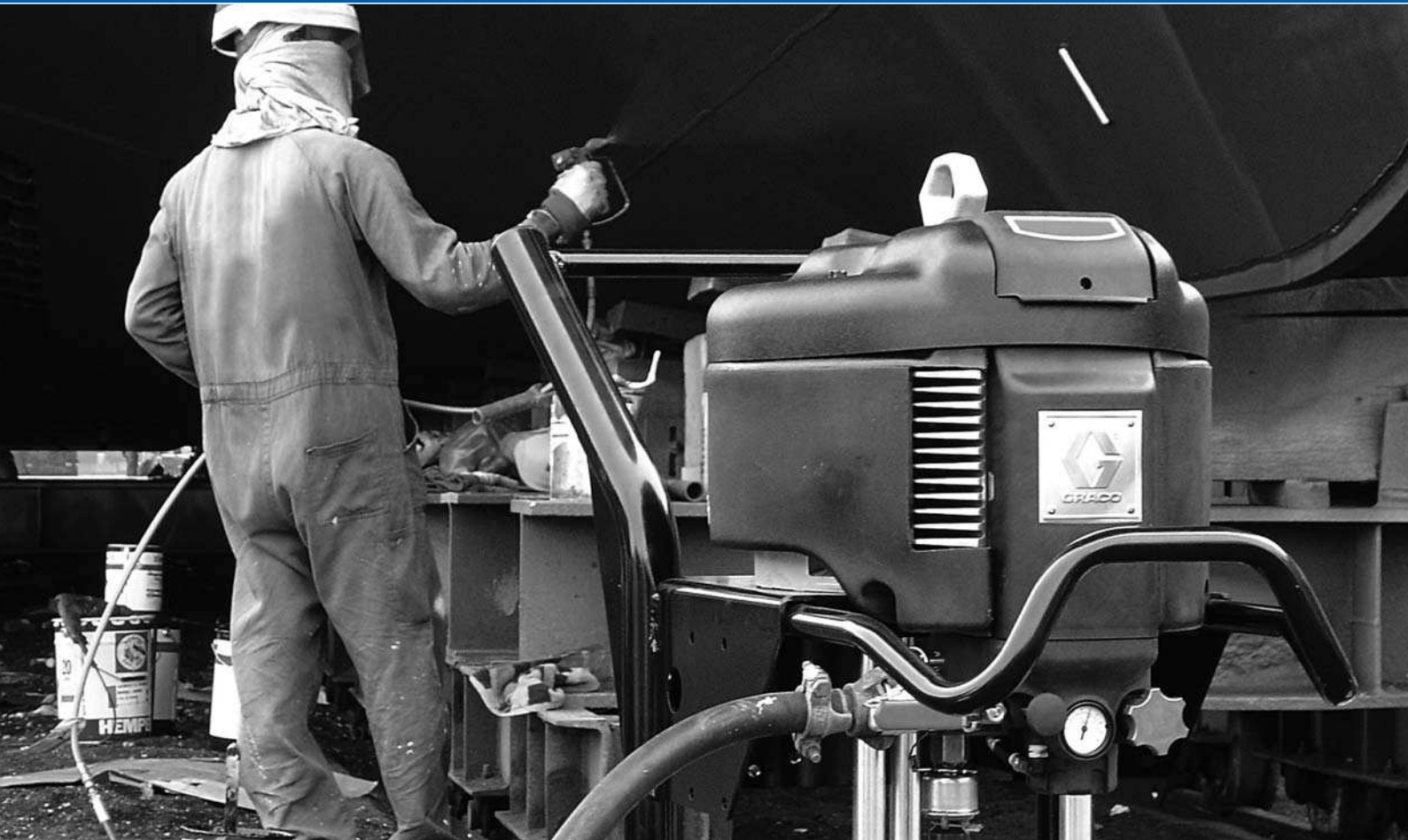

Xtreme[®] Airless Sprayers

The Latest in High-Performance, High-Pressure Technology



Setting the New Industry Standard in Airless Spraying

- Tested to outperform and outlast all other sprayers in the market
- Designed to withstand the harshest environmental conditions
- Easily handles the toughest protective coatings and corrosion control applications
- Provides material tracking, system diagnostics and runaway control
- More configurations mean you get the right tool for any airless spraying job

PROVEN QUALITY. LEADING TECHNOLOGY.

Selecting the Right Xtreme Sprayer

Three new air motor sizes and 11 models to fit all your demanding applications

PACKAGES

X x x x x x

Product Identifier:
X=Xtreme Sprayer

Package Ratio:

25: 3400cc motor/290cc lower	50: 6500cc motor/250cc lower
30: 3400cc motor/220cc lower	55: 3400cc motor/115cc lower
35: 2200cc motor/115cc lower	60: 6500cc motor/220cc lower
40: 3400cc motor/180cc lower	70: 6500cc motor/180cc lower
45: 6500cc motor/290cc lower	90: 6500cc motor/145cc lower
46: 3400cc motor/145cc lower	

Motor Type:

D: De-Icing L: Low Noise

Motor Type:

H: Heavy-Duty Cart W: Wall-Mount

Package/DataTrak:

1: Complete package with DataTrak	4: Bare package without DataTrak
2: Bare package with DataTrak	5: Complete hopper package with DataTrak
3: Complete package without DataTrak	6: Complete hopper package without DataTrak

Example:
X46DH2 is a 46:1, De-Ice, heavy-duty, bare package with DataTrak

Notes: Packages sold with XSeal_LTH packings only. Packages sold with built-in filter only. Complete packages sold with XTR-7 gun, 50 ft x 3/8 hose and 6 ft x 1/4 whip hose. Wall-mount packages are only available bare, but include 10 ft suction hose with 55 gal suction tube.

Use the Smart Numbering System!

The six-digit Smart Numbering System can help you order quickly and accurately. Simply follow the diagram for the part you want and build your order.

PUMPS

P x x x C x

Product Identifier:
P=Xtreme Pump

Pump Ratio:

25: 3400cc motor/290cc lower	50: 6500cc motor/250cc lower
30: 3400cc motor/220cc lower	55: 3400cc motor/115cc lower
35: 2200cc motor/115cc lower	60: 6500cc motor/220cc lower
40: 3400cc motor/180cc lower	70: 6500cc motor/180cc lower
45: 6500cc motor/290cc lower	90: 6500cc motor/145cc lower
46: 3400cc motor/145cc lower	

Motor/DataTrak:

D: De-Icing: None L: Low Noise: None
E: De-Icing: DataTrak M: Low Noise: DataTrak

Lower Material:
C: Carbon Steel

Filter/Air Controls:

1: No built-in filter, no air controls	3: No built-in filter, air controls
2: Built-in filter, no air controls	4: Built-in filter, air controls

Example:
P70DC2 is a 70:1 De-Ice, with built-in filter and no air control

Note: Packages sold with XSeal_LTH packings only.

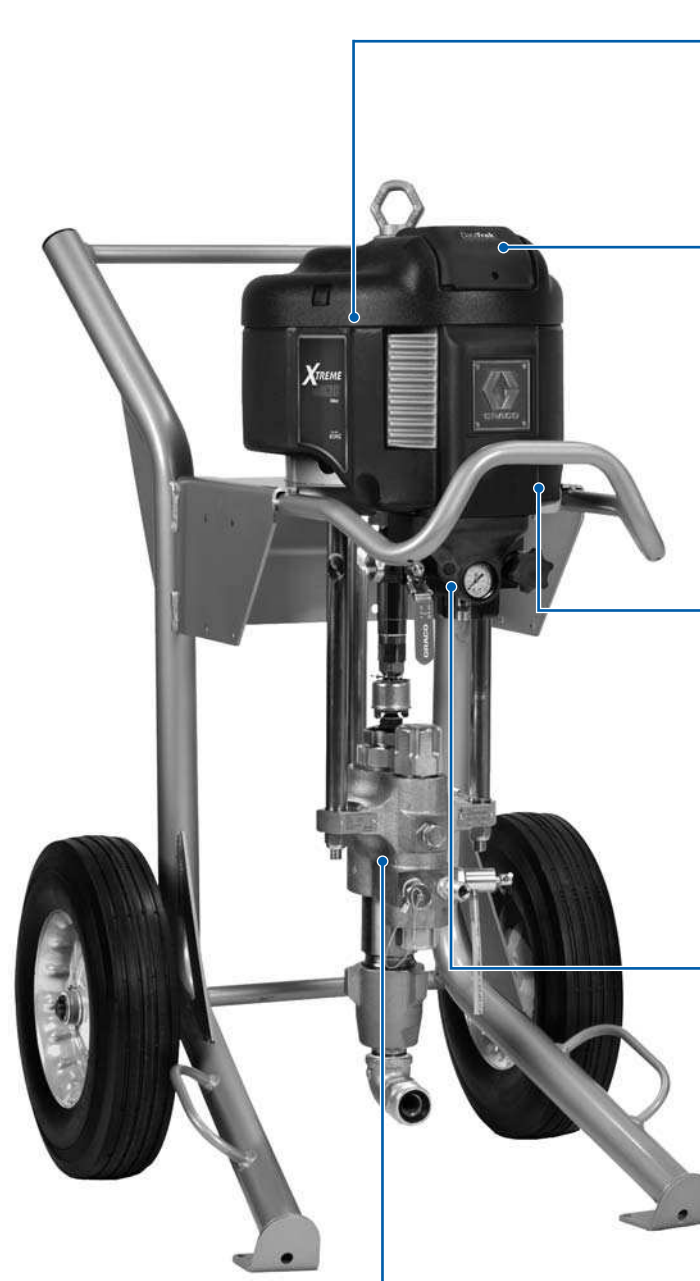

NEW NXT Air Motor

- Modular design for easier maintenance
- Rugged body armor won't rust or dent
- Highest technology air motor on the market

NEW DataTrak™ Control

- Runaway protection
- Pump diagnostics
- Material usage
- Optional accessory



NEW Modular Air Valve

- De-ice controls eliminate icing
- Up to 50% quieter than previous models
- Modular air valve
 - Eliminates stalling
 - Easy-to-repair



NEW Integrated Air Controls

- Easy-turn regulator
- Front-mounted for convenient access
- Compact and modular
- Built-in filtration



Graco Xtreme Pump Lower with Built-In Filter

- Uses half the solvent of other sprayers
- Longer-lasting rod

Xtreme Lowers



LOWERS

L x x x C x

Product Identifier:
L = Xtreme Lower

Lower Volume:

085: 85cc Xtreme	220: 220cc Xtreme
115: 115cc Xtreme	250: 250cc Xtreme
145: 145cc Xtreme	290: 290cc Xtreme
180: 180cc Xtreme	

Lower Material:
C: Carbon Steel

Filter/Packings:

1: No built-in filter with Xtreme Seal (3) Leather (2)
2: Built-in filter with Xtreme Seal (3) Leather (2)
3: No built-in filter with TuffStack (5)
4: Built-in filter with TuffStack (5)

Example:
L115C1 is a 115cc Xtreme lower with no built-in filter

Replacement Screen Filter Elements

2-Pack	25-Pack	Description
224458	238436	30 mesh (595 micron)
224459	238438	60 mesh (250 micron)
224469	238440	100 mesh (149 micron)



	X25	X30	X35	X40	X45	X46	X50	X55	X60	X70	X90
XTREME SPRAYER SPECIFICATIONS											
Output per cycle	290cc	220cc	115cc	180cc	290cc	145cc	250cc	115cc	220cc	180cc	145cc
Motor Size	NXT 3400	NXT 3400	NXT 2200	NXT 3400	NXT 6500	NXT 3400	NXT 6500	NXT 3400	NXT 6500	NXT 6500	NXT 6500
Maximum Working Pressure psi (bar, MPa)	2375 (164, 16.4)	3150 (217, 21.7)	3800 (262, 26.2)	3800 (262, 26.2)	4550 (313, 31.3)	4750 (327, 32.7)	5200 (359, 35.9)	5950 (410, 41.0)	6000 (417, 41.7)	7250 (500, 50.0)	7250 (500, 50.0)
Maximum Air Input Pressure psi (bar, MPa)	100 (7, 0.7)	100 (7, 0.7)	100 (7, 0.7)	100 (7, 0.7)	100 (7, 0.7)	100 (7, 0.7)	100 (7, 0.7)	100 (7, 0.7)	100 (7, 0.7)	100 (7, 0.7)	80 (5.4, .54)
Maximum Free Flow Output gpm (lpm)	13.8 (52.2)	10.0 (38)	6.0 (22.7)	8.5 (32)	13.8 (52.2)	7.5 (28)	11.3 (43)	6.0 (22.7)	10.0 (38)	8.5 (32)	7.5 (28)
Output at 60 CPM gpm (lpm)	4.6 (17)	3.4 (12.9)	2.0 (7.6)	2.9 (11.0)	4.6 (17)	2.3 (8.7)	4.0 (15.2)	2.0 (7.6)	3.4 (12.9)	2.9 (11.0)	2.3 (8.7)

Ordering Information & Accessories



To get genuine Graco accessories, see your nearest Graco Distributor, or call Graco on +32 (89) 770 700.

Xtreme-Duty High-Pressure Hoses

4500 psi

5600 psi

7250 psi



H x x x x x

HOSES

Product Identifier:

H = Hose

Pressure Rating:

4: 4500 psi 7: 7250 psi
5: 5600 psi

Hose Diameter:

25: 1/4 in (6.4 mm) 50: 1/2 in (12.7 mm)
38: 3/8 in (9.5 mm)

Length:

03: 3 ft (0.9 m) 25: 25 ft (7.6 m)
06: 6 ft (1.8 m) 50: 50 ft (15.2 m)
10: 10 ft (3.0 m) 1X: 100 ft (30.5 m)

*Example:
H53850 is a 5600 psi,
3/8 in, 50 ft hose*

Choose the Right Hose for the Job

Technical Specifications

Working pressure	4500 psi (31 MPa)
	5600 psi (38.6 MPa)
	or 7250 psi (50 MPa)
Temperature rating (all sizes)	-40° to 180° F (-40° to 82°C)
Chemical resistance	Hose cover resistant to a wide, variety of solvents, acids and bases
Weather resistance	Hose cover has outstanding resistance to oxygen, ozone, sunlight and general weather conditions
Electrical properties	Conductive hose

Xtreme NXT Spray Accessories



Part #	Description
288347	Hopper Feed Kit
255143	Wall-Mount Bracket
245132	Xtreme Floor-Stand Kit
NXT021	Integrated Air Control Module
NXT093	Coalescing Filter with Manual Drain for Integrated Air Control
NXT094	Coalescing Filter with Auto Drain for Integrated Air Control
NXT206	DataTrak Upgrade Kit for the NXT 2200
NXT306	DataTrak Upgrade Kit for the NXT 3400
NXT606	DataTrak Upgrade Kit for the NXT 6500
NXT107	NXT Air Motor Valve – fits all three sizes
NXT102	De-Ice Control Repair Kit

Part #	Description
NXT112	De-Ice Control (5-Pack)
NXT100	Replacement Poppet Valve Kit
181072	Round Suction Tube Strainer
191635	Tube Strainer
245176	Suction Kit
245136	55 gal (200 l) suction tube extension,
210657	Ball Valve Inlet: 1/4 npt(m), Outlet: 1/4 npt(m)
210658	Ball Valve Inlet: 3/8 npt(m), Outlet: 3/8 npt(m)
210659	Ball Valve Inlet: 1/4 npt(m), Outlet: 3/8 npt(m)
245190	Inlet Ball Spring Load Kit: 145cc, 180cc
245191	Inlet Ball Spring Load Kit: 220cc, 250cc, 290cc

XTR-7 Airless Guns & Accessories



XTR-7 Airless Spray Gun

248609	Round handle, 2-finger trigger, GHD tip guard, No tip
248610	Round handle, 4-finger trigger, 519 flat tip
248611	Oval-insulated handle, 4-finger trigger, 519 GHD RAC tip

248612	Oval-insulated handle, two-finger trigger, 519 GHD RAC tip
248613	Round handle, four-finger trigger, 519 GHD RAC tip
248614	Round handle, two-finger trigger, 519 GHD RAC tip

Accessories

287450	2-finger trigger kit
287449	4-finger round trigger kit
287451	4-finger oval insulation trigger kit
246294	10 in (254 mm) gun extension, 7250 psi (500 bar, 50 MPa)
246295	15 in (380 mm) gun extension, 7250 psi (500 bar, 50 MPa)
246296	18 in (457 mm) gun extension, 7250 psi (500 bar, 50 MPa)

246297	180° spray nozzle, 7/8-14 UNC-2B, 7250 psi (500 bar, 50 MPa)
248837	Gun repair kit, includes gasket, needle and seat
245994	GHD tip guard kit
287032	Filter, 60 mesh
287033	Filter, 100 mesh
287034	Filter, 60 and 100 mesh combination