



introduction

Lionweld Kennedy's history can be traced back to 1910 when P.A. Mudd and Company were one of the first electric arc welding companies in Britain, almost 20 years later Lionweld Steel Flooring and Stairway Company was formed. 1988 saw the merger of Lionweld Flooring and Alan Kennedy & Co. Ltd who became one of the largest manufacturers of open steel flooring in the UK.

Hill & Smith Holdings Plc acquired Lionweld Kennedy in 2004, provided significant improvements and invested heavily in new and improved machinery. Lionweld Kennedy is now growing from strength to strength servicing the construction, engineering and offshore industries with it's exceptional products and services.

Quality control and high levels of service are the fundamentals upon which the company has earned its reputation as a market leader. As a registered ISO9001 company, Lionweld Kennedy offers the highest standards and best in class practices in all they do.

All open steel flooring is manufactured in Lionweld Kennedy's modern facilities based in the north east of England.



subsidiary of Hill and Smith Holdings Plc



contents

introduction to Lionweld Kennedy	02
terminology	04
fabricated grating categories	05
surfaces & finishes	06

Safegrid

Safegrid has become the industry standard for many open steel flooring applications, including walkways, platforms & gantries.



Safety Grating

A variation of Safegrid flooring designed to prevent a 15mm ball from passing through the floor.



Safegrate

A heavy duty flooring designed to endure vehicle loadings or any application where extra heavy loads need to be sustained.



Safelock

Usually supplied with a double serration, Safelock is the most slip resistant flooring suitable for extreme conditions in applications such as the offshore industry.



Safetread / Diamond Pattern

One of the most original styles of flooring used throughout the world, Safetread is an extremely strong and aesthetically pleasing design.



Safedeck

A Safegrid flooring with a floor plate welded to the top surface providing a strong, enclosed flooring option.



Stanweld

A series of pyramid 'T' bars formed to provide a large surface area giving an excellent feeling of security under foot.



Fixings

Steel flooring can be fixed into position using various types of fixing clips, Lionweld Kennedy offer a full range of removable and positive fixings.

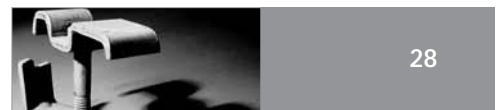

treads

Stairtreads

Made from any of our flooring types to ensure any stairways match the flooring design. A nosing bar is welded to the front for extra grip and acts as a site bar.



handrailing

Saferail

A handrail system comprising of upright stanchions and horizontal runs of handrail tube. Can be supplied as loose sections or a fully welded frame.



terminology

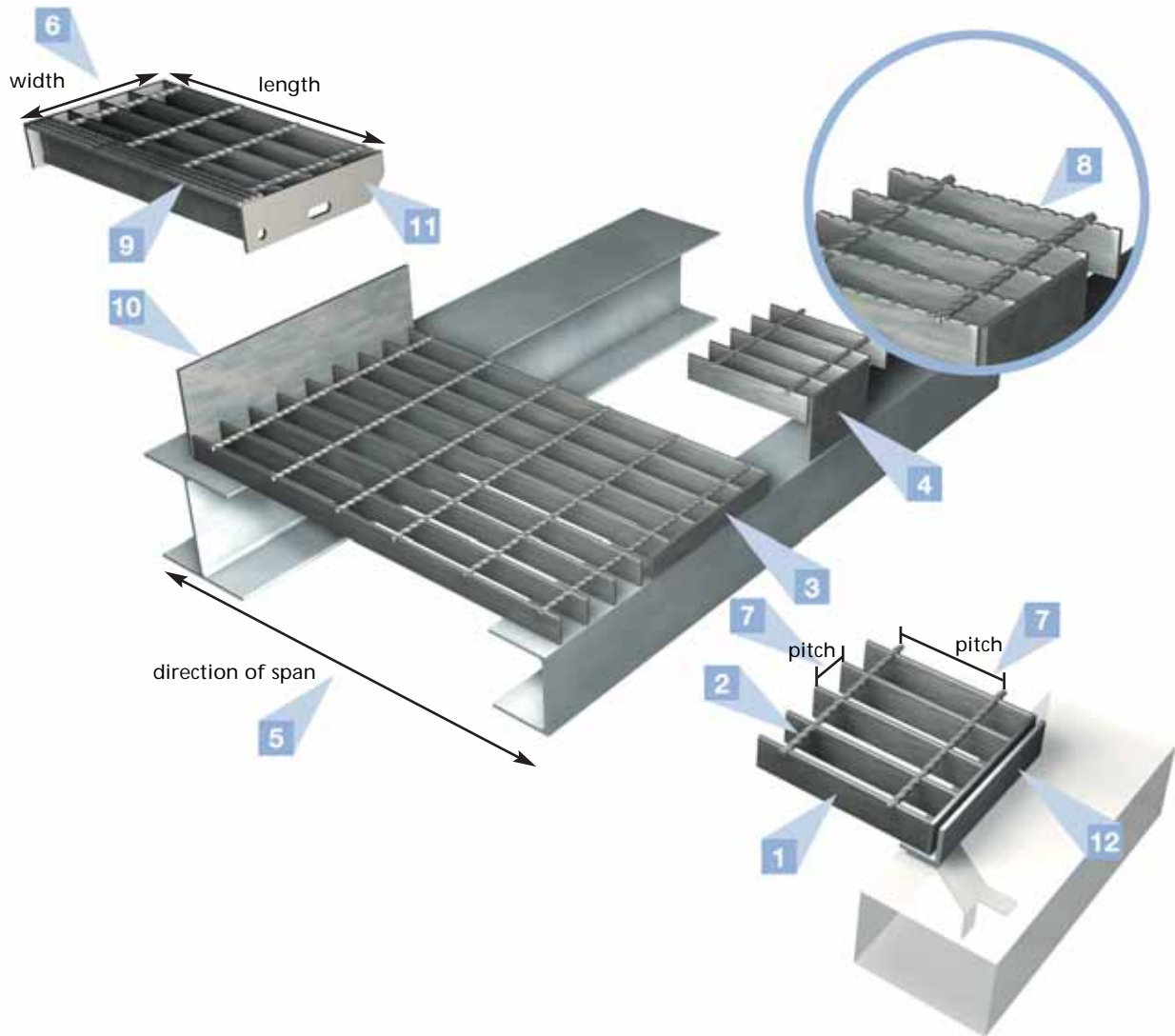

1 Load Bearing Bar

A load bearing member spanning between supports.

2 Transverse Bar

A member fixed perpendicular to the load bearing bars.

3 Binding Bar

A bar or section fixed to the edge of a flooring panel flush with the top of the load bearing bars.

4 Deep Binding Bar

A bar section, of greater depth than the load bearing bar, fixed to the edge of a flooring panel and projecting below the underside.

5 Length (Direction of Span).

The overall dimension of a flooring panel parallel with the load bearing bars. (this dimension is always referred to as 'length' even if it is shorter than the width).

6 Width

The overall dimension of a flooring panel measured perpendicular to the load bearing bars.

7 Pitch

The distance centre-to-centre of load bearing bars or centre-to-centre of transverse bars.

8 Serrations

Notches formed in the top surface of the load bearing bars to improve slip resistance.

9 Nosing Bar

A slip resistant member attached to the front of a stair tread or flooring panel.

10 Toe Plate (Kick-Plate)

A flat bar welded to a flooring panel projecting above the top of the load bearing bars.

11 End Plate

A plate welded to a stairtread for fixing to a stringer.

12 Curb Angle

A rolled steel angle (RSA) fixed to concrete to support flooring.

fabricated grating categories

Lionweld Kennedy grating is manufactured in standard stock sizes. These panels are then fabricated to suit specific applications.

Standard Steel Panels Sizes

- Safegrid 6m x 1m (nominal)
- Safety Grating 6m x 1m (nominal)
- Safelock 3m x 1m (nominal)
- Safetread / Diamond Pattern 3m x 0.8m

Note: Safegrate, Safedeck & Stanweld are manufactured to suit.

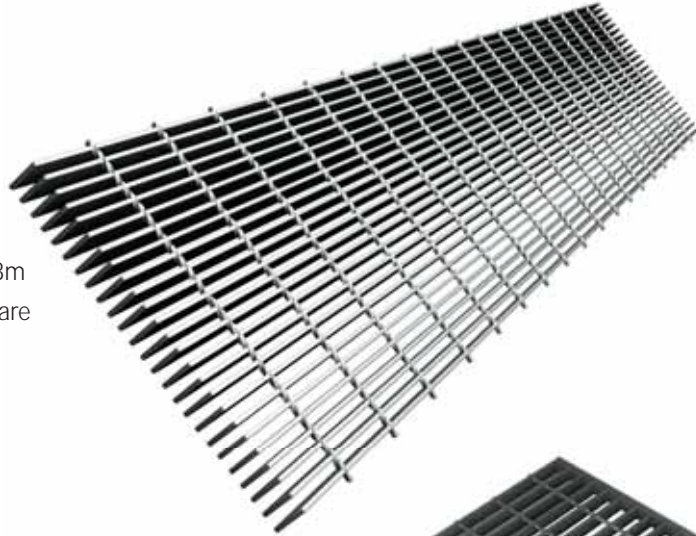

Cut and Bind

- a** Standard width panels
- b** Runs of panels can have 1 no. made to width panel i.e. a panel which is smaller or bigger than the standard width to make up the walkway overall length
- c** No cut-outs or panel notching
- d** Panel ends bound with binding bars of the same depth as the bearing bars
- e** Toe plate can replace binding bars at additional cost
- f** Most cost effective fabrication

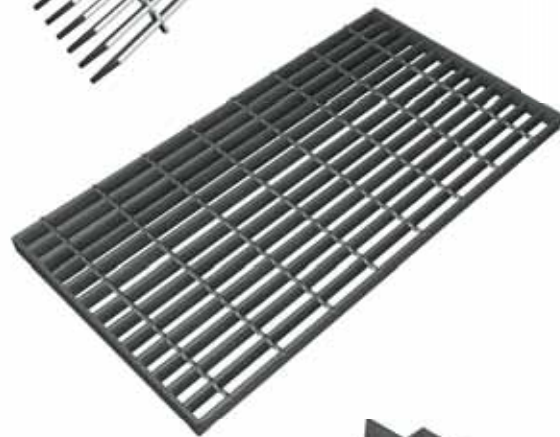

Simple Layout

- a** Generally standard width panels, but areas supplied with non-standard widths to suit application
- b** Nominal amounts of panel shaping and cut-outs
- c** Panel ends and cut-outs bound with binding bars of the same depth as the bearing bars
- d** Toe plate can replace binding bars at additional cost

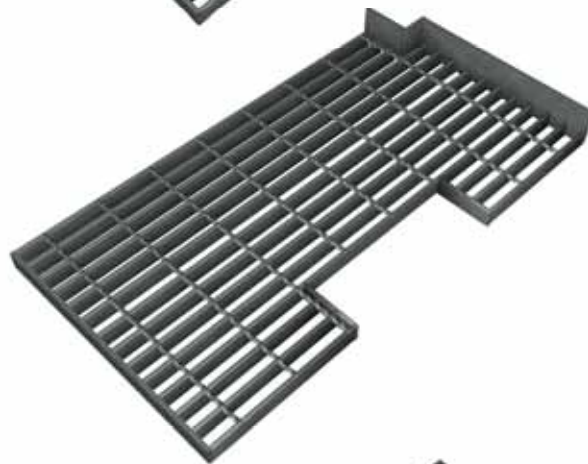

Annular / Complex Layout

- a** Generally standard width panels, but areas supplied with non-standard widths to suit application
- b** Large amounts of panel shaping and cut-outs
- c** Panel ends and cut-outs bound with binding bars of the same depth as the bearing bars
- d** Toe plate can replace binding bars at additional cost



flooring surfaces

Plain 
open grid flooring

- Safegrid
- Safety Grating
- Safegrate
- Safelock
- Safetread



Landed Flat 
(machine serration)
transverse bars
bedded into the
steel below the
serration line.

- Safegrid
- Safety Grating



Rolled Serrated 
increased slip resistance

- Safegrid
- Safety Grating
- Safegrate
- Safetread



Double Serration 
(machine serration)
load bearing bars
and the transverse bars
are machine serrated.

- Safelock



Machine Serrated 
deeper, more abrasive
serration

- Safegrid
- Safety Grating
- Safegrate
- Safetread



flooring finishes and materials

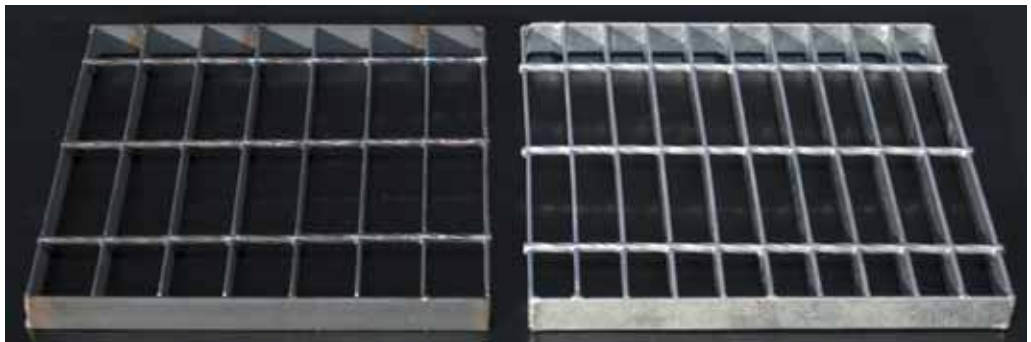

All flooring is manufactured from material grade S275JR as standard. Other materials are available on request.

Lionweld Kennedy Flooring is available in either:

 **Self Colour** - Allows for on-site fabrication and improved delivery times.

 **Galvanised** - Hot Dipped Galvanised to BS EN ISO 1461-2009.

safegrid

Lionweld Kennedy Safegrid open bar grating comprises of a series of parallel flat load bearing bars at equal spacings.

The load bearing bars are held upright at regular spaced intervals by 6mm square twisted transverse bars that are resistance welded into the top surface.

The transverse bars are assumed not to contribute to the load carrying capabilities of the load bearing bars.

Safegrid is our standard and most common type of flooring.

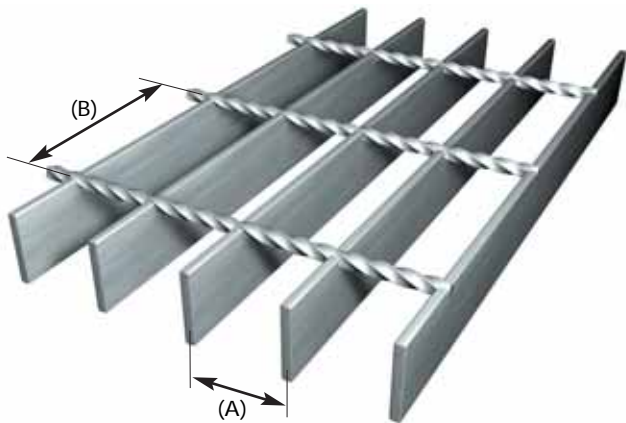

Safegrid	
Load Bearing bar centres (A)	Transverse bar centres (B)
W (41mm)	50 , 100 (mm)
N (30mm)	50 , 100 (mm)
E (33mm)	50 , 100 (mm)
NX (20mm)	50 , 100 (mm)
Surfaces Available <small>see page 06</small>	
Plain	
Rolled Serrated	
Machine Serrated	
Landed Flat	

Fixings Recommended for Safegrid Flooring:

Removable Fixing

- Saddle Clip
- Narrow Clip (type NX only)
- Universal Deep Saddle Clip

Positive Fixing

- Deep Saddle with self tapping bolt
- Fixing pads

see page 28 for further details

safegrid – type W plain

max clear span for pedestrian loadings (mm)	def (mm)	L.B.B. size (mm)	'W' load bars at 41mm centres														Self Colour Weights per square metre (kgs)	Binding Bar Weight (based on 2 x 1m) (kgs)	
			clear span (mm)																
				300	450	600	750	900	1050	1200	1350	1500	1650	1800	1950	2100			
a.890	4.36	20 x 3	kN/m2	79.0	35.0	18.2	9.30											13.41	0.86
b.890	4.36		D (mm)	0.81	1.82	3.00	3.75												
c.800	3.90		D (mm)	0.81	1.82	3.00	3.75												
a.1240	6.11	25 x 3	kN/m2	124	55.0	31.0	18.2	10.5	6.60	4.40								16.16	1.08
b.1150	5.69		D (mm)	0.65	1.47	2.61	3.75	4.50	5.25	6.00									
c.1000	4.88		D (mm)	0.65	1.47	2.61	3.75	4.50	5.25	6.00									
a.1560	7.08	30 x 3	kN/m2	179	79.0	44.0	28.5	18.2	11.5	7.65	5.38	3.93						18.91	1.30
b.1385	6.92		D (mm)	0.55	1.22	2.15	3.35	4.50	5.25	6.00	6.75	7.50							
c.1200	5.85		D (mm)	0.55	1.22	2.15	3.35	4.50	5.25	6.00	6.75	7.50							
a.1910	9.46	35 x 3	kN/m2	244	108	61.0	38.9	27.0	18.2	12.2	8.56	6.25	4.69					21.41	1.50
b.1615	8.06		D (mm)	0.47	1.05	1.87	2.92	4.19	5.25	6.00	6.75	7.50	8.25						
c.1410	7.03		D (mm)	0.47	1.05	1.87	2.92	4.19	5.25	6.00	6.75	7.50	8.25						
a.2140	10.0	40 x 3	kN/m2	319	141	79.7	50.9	35.2	25.8	18.2	12.8	9.32	7.0	5.39	4.24			24.16	1.94
b.1845	9.20		D (mm)	0.41	0.92	1.64	2.56	3.67	5.00	6.00	6.75	7.50	8.25	9.00	9.75				
c.1610	8.00		D (mm)	0.41	0.92	1.64	2.56	3.67	5.00	6.00	6.75	7.50	8.25	9.00	9.75				

max clear span for pedestrian loadings (mm)	def (mm)	L.B.B. size (mm)	'W' load bars at 41mm centres														Self Colour Weights per square metre (kgs)	Binding Bar Weight (based on 2 x 1m) (kgs)	
			clear span (mm)																
				300	450	600	750	900	1050	1200	1350	1500	1650	1800	1950	2100			
a.1150	5.70	20 x 5	kN/m2	133	59.0	30.3	15.5	8.90	5.60									21.41	1.50
b.1090	5.38		D (mm)	0.82	1.84	3.00	3.75	4.50	5.25										
c.950	4.66		D (mm)	0.82	1.84	3.00	3.75	4.50	5.25										
a.1540	7.06	25 x 5	kN/m2	206	92.0	51.0	30.0	17.5	11.05	7.40	5.20	3.79						25.91	1.86
b.1360	6.68		D (mm)	0.04	0.16	0.40	0.79	4.50	5.25	6.00	6.75	7.50							
c.1190	5.87		D (mm)	0.04	0.16	0.40	0.79	4.50	5.25	6.00	6.75	7.50							
a.1940	9.60	30 x 5	kN/m2	299	132	74.5	47.5	30.3	19.1	12.8	8.98	6.56	4.92	3.79				30.66	2.24
b.1640	8.17		D (mm)	0.55	1.22	2.18	3.39	4.50	5.25	6.00	6.75	7.50	8.25	9.00					
c.1430	7.08		D (mm)	0.55	1.22	2.18	3.39	4.50	5.25	6.00	6.75	7.50	8.25	9.00					
a.2200	10.0	35 x 5	kN/m2	407	181	101	64.9	44.9	30.3	20.3	14.3	10.4	7.82	6.02	4.74			35.41	2.60
b.1915	9.56		D (mm)	0.47	1.06	1.86	2.92	4.19	5.24	6.00	6.75	7.50	8.25	9.00	9.75				
c.1670	8.30		D (mm)	0.47	1.06	1.86	2.92	4.19	5.24	6.00	6.75	7.50	8.25	9.00	9.75				
a.2310	10.0	40 x 5	kN/m2	532	236	132	84.0	58.0	43.0	30.3	21.3	15.5	11.7	8.99	7.07	5.39		39.91	2.98
b.2140	10.0		D (mm)	0.41	0.92	1.63	2.53	3.63	5.00	6.00	6.75	7.50	8.25	9.00	9.75	10.0			
c.1910	9.51		D (mm)	0.41	0.92	1.63	2.53	3.63	5.00	6.00	6.75	7.50	8.25	9.00	9.75	10.0			
a.2550	10.0	45 x 5	kN/m2	670	299	168	107	74.5	54.6	41.7	30.3	22.1	16.7	12.8	10.1	7.68		44.66	3.36
b.2335	10.0		D (mm)	0.36	0.82	1.46	2.27	3.27	4.44	5.79	6.75	7.50	8.25	9.00	9.75	10.0			
c.2110	10.0		D (mm)	0.36	0.82	1.46	2.27	3.27	4.44	5.79	6.75	7.50	8.25	9.00	9.75	10.0			
a.2790	10.0	50 x 5	kN/m2	830	409	207	132	92.0	67.5	51.5	40.6	30.3	22.8	17.6	13.8	10.5		49.16	3.72
b.2530	10.0		D (mm)	0.33	0.61	1.31	2.04	2.94	4.00	5.21	6.58	7.50	8.25	9.00	9.75	10.0			
c.2280	10.0		D (mm)	0.33	0.61	1.31	2.04	2.94	4.00	5.21	6.58	7.50	8.25	9.00	9.75	10.0			
a.3260	10.0	60 x 5	kN/m2	1199	530	299	191	132	97.3	74.3	58.6	47.3	39.0	30.4	23.9	18.2		58.66	4.48
b.2900	10.0		D (mm)	0.27	0.61	1.09	1.71	2.44	3.34	4.35	5.49	6.76	8.17	9.00	9.75	10.0			
c.2620	10.0		D (mm)	0.27	0.61	1.09	1.71	2.44	3.34	4.35	5.49	6.76	8.17	9.00	9.75	10.0			

Safe uniformly distributed loads (U.D.L.) in kilonewtons per square metre on simply supported panels with deflections (δ) in mm. Based on a working stress of 180 N/mm². Loads shown in the white area have been reduced to keep the deflections within 1/200th of the clear span or 10mm whichever is the lesser. **Please contact Lionweld Kennedy sales team for Serrated Load Tables.**

a – Light Duty 3 kN/m² described as access limited to one person only

b – General Duty 5 kN/m² described as regular two way pedestrian traffic

c – Heavy Duty 7.5 kN/m² described as high density pedestrian traffic

Load Table Designs allow for a 1kN load over a 300mm x 300mm area in accordance with BS 4592-0:2006

Weights shown are for transverse bars at 100mm centres. For 50mm centres add 2.4kg per M²

safegrid – type N plain

max clear span for pedestrian loadings (mm)	def (mm)	L.B.B. size (mm)	'N' load bars at 30mm centres														Self Colour Weights per square metre (kgs)	Binding Bar Weight (based on 2 x 1m) (kgs)		
			clear span (mm)																	
				300	450	600	750	900	1050	1200	1350	1500	1650	1800	1950	2100				
a.1050	3.41	20 x 3	kN/m2	108	48.0	24.7	12.6	7.3											17.58	0.86
b.1020	5.06		D (mm)	0.82	1.84	2.99	3.72	4.47												
c. 890	4.40																			
a.1450	6.34	25 x 3	kN/m2	169	75.0	42.0	24.7	14.3	9.01	6.05	4.24								21.02	1.08
b.1275	6.32		D (mm)	0.65	1.47	2.60	3.74	4.49	5.25	6.00	6.75									
c.1110	5.45																			
a.1815	9.01	30 x 3	kN/m2	243	108	60.7	38.5	24.7	15.6	10.5	7.34	5.35	4.02						24.76	1.30
b.1535	7.68		D (mm)	0.54	1.23	2.18	3.37	4.50	5.25	6.00	6.75	7.50	8.25							
c.1340	6.69																			
a.1980	9.90	35 x 3	kN/m2	332	147	82.9	53.0	36.7	24.8	16.6	11.7	8.50	6.38	4.91	3.86				28.16	1.50
b.1790	8.95		D (mm)	0.47	1.05	1.87	2.92	4.20	5.25	6.00	6.75	7.50	8.25	9.00	9.75					
c.1560	7.74																			
a.2190	10.0	40 x 3	kN/m2	434	193	108	69.0	48.0	35.0	24.8	17.4	12.7	9.53	7.34	5.77	4.40			31.90	1.72
b.2030	9.91		D (mm)	0.41	0.92	1.63	2.55	3.68	4.97	6.00	6.75	7.50	8.25	9.00	9.75	10.0				
c.1780	8.79																			

max clear span for pedestrian loadings (mm)	def (mm)	L.B.B. size (mm)	'N' load bars at 30mm centres														Self Colour Weights per square metre (kgs)	Binding Bar Weight (based on 2 x 1m) (kgs)		
			clear span (mm)																	
				300	450	600	750	900	1050	1200	1350	1500	1650	1800	1950	2100				
a.1350	5.58	20 x 5	kN/m2	181	80.0	41.3	21.1	12.2	7.70	5.10									28.16	1.50
b.1210	6.01		D (mm)	0.82	1.84	3.00	3.75	4.49	5.25	6.00										
c.1055	5.21																			
a.1790	8.84	25 x 5	kN/m2	282	125	70.0	41.2	23.9	15.1	10.1	7.08	5.16	3.88						34.32	1.86
b.1510	7.46		D (mm)	0.66	1.47	2.60	3.74	4.50	5.25	6.00	6.75	7.50	8.25							
c.1320	6.53																			
a.2010	10.0	30 x 5	kN/m2	405	180	101	64.5	41.3	26.0	17.4	12.2	8.92	6.70	5.16	4.60				40.74	2.24
b.1815	9.01		D (mm)	0.54	1.23	2.17	3.39	4.50	5.25	6.00	6.75	7.50	8.25	9.00	9.75					
c.1580	7.76																			
a.2260	10.0	35 x 5	kN/m2	554	246	138	88.3	61.2	41.3	27.7	19.4	14.2	10.6	8.19	6.44	4.91			46.86	2.60
b.2090	10.0		D (mm)	0.47	1.05	1.87	2.92	4.20	5.25	6.00	6.75	7.50	8.25	9.00	9.75	10.0				
c.1850	9.19																			
a.2520	10.0	40 x 5	kN/m2	722	311	180	115	80.0	58.6	41.3	29.0	21.1	15.9	12.2	9.62	7.33			53.32	2.98
b.2310	10.0		D (mm)	0.41	0.89	1.63	2.55	3.68	4.99	6.00	6.75	7.50	8.25	9.00	9.75	10.0				
c.2080	9.83																			
a.2790	10.0	45 x 5	kN/m2	917	405	228	146	101	74.0	55.0	41.3	30.1	22.6	17.4	13.7	10.5			59.78	3.36
b.2525	10.0		D (mm)	0.37	0.82	1.45	2.27	3.26	4.43	5.61	6.75	7.50	8.25	9.00	9.75	10.0				
c.2280	10.0																			
a.3050	10.0	50 x 5	kN/m2	1130	503	282	180	125	91.0	70.0	55.2	41.2	31.0	23.9	18.8	14.3			65.90	3.72
b.2730	10.0		D (mm)	0.33	0.74	1.31	2.04	2.94	3.97	5.21	6.58	7.50	8.25	9.00	9.75	10.0				
c.2760	10.0																			
a.3550	10.0	60 x 5	kN/m2	1630	718	407	260	180	132	101	79.5	64.4	53.1	41.3	32.5	24.8			78.82	4.48
b.3130	10.0		D (mm)	0.27	0.61	1.09	1.71	2.46	3.34	4.35	5.48	6.77	8.17	9.00	9.75	10.0				
c.2830	10.0																			

Safe uniformly distributed loads (U.D.L.) in kilonewtons per square metre on simply supported panels with deflections (δ) in mm. Based on a working stress of 180 N/mm². Loads shown in the white area have been reduced to keep the deflections within 1/200th of the clear span or 10mm whichever is the lesser. **Please contact Lionweld Kennedy sales team for Serrated Load Tables.**

a – Light Duty 3 kN/m² described as access limited to one person only

b – General Duty 5 kN/m² described as regular two way pedestrian traffic

c – Heavy Duty 7.5 kN/m² described as high density pedestrian traffic

Load Table Designs allow for a 1kN load over a 300mm x 300mm area in accordance with BS 4592-0:2006

Weights shown are for transverse bars at 100mm centres. For 50mm centres add 2.4kg per M²

safegrid – type E plain

max clear span for pedestrian loadings (mm)	def (mm)	L.B.B. size (mm)	'E' load bars at 33mm centres														Self Colour Weights per square metre (kgs)	Binding Bar Weight (based on 2 x 1m) (kgs)	
			clear span (mm)																
				300	450	600	750	900	1050	1200	1350	1500	1650	1800	1950	2100			
a.1000	3.07	20 x 3	kN/m2	99.0	43.6	22.5	11.6	6.69										16.82	0.86
b. 990	4.92		D (mm)	0.81	1.82	3.00	3.75	4.50											
c. 865	4.30																		
a.1390	5.87	25 x 3	kN/m2	154	68.5	38.5	22.6	13.1	8.23	5.51	3.87							21.08	1.08
b.1235	6.10		D (mm)	0.65	1.47	2.62	3.75	4.50	5.25	6.00	6.75								
c.1080	5.35																		
a.1700	8.30	30 x 3	kN/m2	222	98.7	35.5	35.3	22.6	14.2	9.53	6.69	4.88	3.66					24.14	1.30
b.1485	7.38		D (mm)	0.55	1.23	3.40	3.39	4.50	5.25	6.00	6.75	7.50	8.25						
c.1295	6.40																		
a.1980	8.81	35 x 3	kN/m2	303	134	75.5	48.3	33.5	22.6	15.1	10.6	7.75	5.82	4.48				28.35	1.50
b.1730	8.56		D (mm)	0.47	1.05	1.87	2.92	4.20	5.25	6.00	6.75	7.50	8.25	9.00					
c.1515	7.55																		
a.2140	10.0	40 x 3	kN/m2	396	176	98.5	63.0	43.5	32.0	22.6	15.9	11.6	8.70	6.69	5.26	4.01		31.32	1.72
b.1980	9.84		D (mm)	0.41	0.92	1.63	2.55	3.65	4.98	6.00	6.75	7.50	8.25	9.00	9.75	10.00			
c.1730	8.60																		

max clear span for pedestrian loadings (mm)	def (mm)	L.B.B. size (mm)	'E' load bars at 33mm centres														Self Colour Weights per square metre (kgs)	Binding Bar Weight (based on 2 x 1m) (kgs)	
			clear span (mm)																
				300	450	600	750	900	1050	1200	1350	1500	1650	1800	1950	2100			
a.1285	5.03	20 x 5	kN/m2	165	73.1	37.6	19.3	11.1	7.02	4.70								26.46	1.50
b.1175	5.86		D (mm)	0.82	1.84	3.00	3.75	4.50	5.25	6.00									
c.1025	5.09																		
a.1690	8.40	25 x 5	kN/m2	257	114	64.2	37.7	21.6	13.7	9.19	6.45	4.70						33.20	1.86
b.1470	7.35		D (mm)	0.66	1.47	2.62	3.75	4.50	5.25	6.00	6.75	7.50							
c.1280	6.34																		
a.1950	9.75	30 x 5	kN/m2	220	98.0	55.0	59.1	37.5	23.7	15.9	11.2	8.13	6.11	4.70				39.30	2.24
b.1760	8.74		D (mm)	0.54	1.22	2.16	3.41	4.50	5.25	6.00	6.75	7.50	8.25	9.00					
c.1540	7.68																		
a.2210	10.0	35 x 5	kN/m2	505	224	126	80.5	55.8	37.7	25.2	17.7	12.9	9.70	7.47	5.87	4.48		45.39	2.60
b.2040	9.93		D (mm)	0.47	1.05	1.87	2.92	4.20	5.25	6.00	6.75	7.50	8.25	9.00	9.75	10.0			
c.1790	8.83																		
a.2460	10.0	40 x 5	kN/m2	660	293	164	105	72.6	53.4	37.6	26.4	19.3	14.5	11.2	8.77	6.69		51.50	2.98
b.2255	10.0		D (mm)	0.41	0.92	1.63	2.55	3.66	4.99	6.00	6.75	7.50	8.25	9.00	9.75	10.0			
c.2040	9.98																		
a.2720	10.0	45 x 5	kN/m2	835	370	208	133	92.0	67.6	51.5	37.7	27.5	20.6	15.9	12.5	9.52		56.87	3.36
b.2465	10.0		D (mm)	0.36	0.82	1.45	2.27	3.26	4.43	5.76	6.75	7.50	8.25	9.00	9.75	10.0			
c.2225	10.0																		
a.2960	10.0	50 x 5	kN/m2	1030	457	257	164	114	83.5	63.8	50.2	37.7	28.3	21.8	17.1	13.1		63.42	3.72
b.2670	10.0		D (mm)	0.33	0.74	1.31	2.04	2.94	3.99	5.20	6.56	7.50	8.25	9.00	9.75	10.0			
c.2410	10.0																		
a.3500	10.0	60 x 5	kN/m2	1480	660	370	236	164	121	92.0	72.6	58.7	48.3	37.7	29.6	22.6		75.84	4.48
b.3060	10.0		D (mm)	0.27	0.62	1.09	1.70	2.45	3.33	4.34	5.49	6.77	8.15	9.00	9.75	10.0			
c.2760	10.0																		

Safe uniformly distributed loads (U.D.L.) in kilonewtons per square metre on simply supported panels with deflections (δ) in mm. Based on a working stress of 180 N/mm². Loads shown in the white area have been reduced to keep the deflections within 1/200th of the clear span or 10mm whichever is the lesser. **Please contact Lionweld Kennedy sales team for Serrated Load Tables.**

a – Light Duty 3 kN/m² described as access limited to one person only

b – General Duty 5 kN/m² described as regular two way pedestrian traffic

c – Heavy Duty 7.5 kN/m² described as high density pedestrian traffic

Load Table Designs allow for a 1kN load over a 300mm x 300mm area in accordance with BS 4592-0:2006

Weights shown are for transverse bars at 100mm centres. For 50mm centres add 2.4kg per M²

safegrid – type NX plain

max clear span for pedestrian loadings (mm)	def (mm)	L.B.B. size (mm)	'NX' load bars at 20mm centres														Self Colour Weights per square metre (kgs)	Binding Bar Weight (based on 2 x 1m) (kgs)	
			clear span (mm)																
				300	450	600	750	900	1050	1200	1350	1500	1650	1800	1950	2100			
a.1223	6.12	20 x 3	kN/m ²	153	68.0	35.0	17.9	10.4	6.52	4.37								26.14	0.86
b.1145	5.69		D (mm)	0.82	1.84	3.00	3.75	4.50	5.25	6.00									
c.1000	4.96																		
a.1704	8.52	25 x 3	kN/m ²	239	107	59.5	34.9	20.2	12.8	8.54	5.99	4.37	3.28					32.15	1.08
b.1430	7.08		D (mm)	0.66	1.48	2.61	3.75	4.50	5.25	6.00	6.75	7.50	8.25						
c.1250	6.20																		
a.1884	9.42	30 x 3	kN/m ²	345	153	86.0	54.6	35.0	22.0	14.8	10.4	7.55	5.67	4.37				38.15	1.30
b.1720	8.58		D (mm)	0.55	1.23	2.18	3.39	4.50	5.25	6.00	6.75	7.50	8.25	9.00					
c.1485	7.41																		

max clear span for pedestrian loadings (mm)	def (mm)	L.B.B. size (mm)	'NX' load bars at 20mm centres														Self Colour Weights per square metre (kgs)	Binding Bar Weight (based on 2 x 1m) (kgs)	
			clear span (mm)																
				300	450	600	750	900	1050	1200	1350	1500	1650	1800	1950	2100			
a.1575	7.87	20 x 5	kN/m ²	255	113	58.3	29.9	17.3	10.9	7.28	5.11	3.73						42.16	1.50
b.1360	6.79		D (mm)	0.82	1.84	3.00	3.75	4.50	5.25	6.00	6.75	7.50							
c.1185	5.87																		
a.1862	9.31	25 x 5	kN/m ²	399	177	99.4	58.3	33.7	21.2	14.2	9.99	7.28	5.47	4.21				52.16	1.86
b.1700	8.49		D (mm)	0.66	1.48	2.62	3.75	4.50	5.25	6.00	6.75	7.50	8.25	9.00					
c.1485	7.41																		
a.2175	10.0	30 x 5	kN/m ²	575	255	143	91.5	58.3	36.7	24.6	17.3	12.6	9.46	7.28	5.73	4.37		62.17	2.24
b.2030	10.0		D (mm)	0.55	1.23	2.18	3.41	4.50	5.25	6.00	6.75	7.50	8.25	9.00	9.75	10.0			
c.1780	8.86																		



Safe uniformly distributed loads (U.D.L.) in kilonewtons per square metre on simply supported panels with deflections (θ) in mm. Based on a working stress of 180 N/mm². Loads shown in the white area have been reduced to keep the deflections within 1/200th of the clear span or 10mm whichever is the lesser. **Please contact Lionweld Kennedy sales team for Serrated Load Tables.**

- a** – Light Duty 3 kN/m² described as access limited to one person only
- b** – General Duty 5 kN/m² described as regular two way pedestrian traffic
- c** – Heavy Duty 7.5 kN/m² described as high density pedestrian traffic

Load Table Designs allow for a 1kN load over a 300mm x 300mm area in accordance with BS 4592-0:2006
Weights shown are for transverse bars at 100mm centres. For 50mm centres add 2.4kg per M²

safety grating

Lionweld Kennedy Safety Grating is designed to prevent a 15mm ball from passing through the flooring.

Safety Grating is a variation of safegrid flooring with a 9mm intermediate round bar welded to the underside of the transverse bars.

Safety Grating is usually supplied with a serrated surface and is used in varying applications where it is necessary to prevent small objects such as nuts, bolts and tools from passing through the flooring.

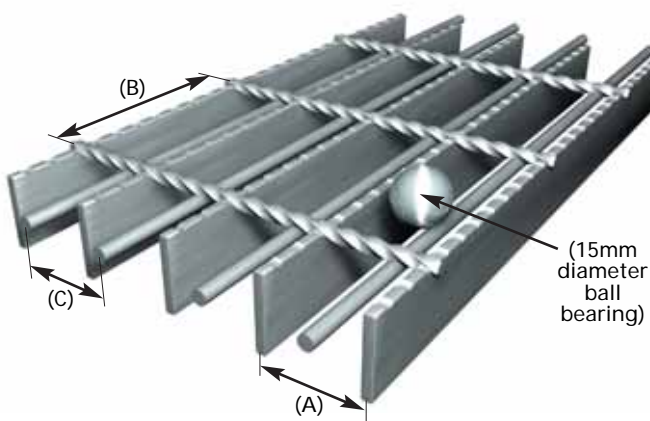

Safety Grating		
Load Bearing bar centres (A)	Transverse bar centres (B)	Round Bar (9mm) centres (C)
W (41mm)	50 , 100 (mm)	41mm
N (30mm)	50 , 100 (mm)	30mm
Surfaces Available <small>see page 06</small>		
Plain		
Rolled Serrated		
Machine Serrated		
Landed Flat		

Fixings Recommended for Safety Grating:

Removable Fixing

- SG1 Clip

Positive Fixing

- Fixing pads

see page 28 for further details

safety grating – type W plain

max clear span for pedestrian loadings (mm)	def (mm)	L.B.B. size (mm)	'W' load bars at 41mm centres														Self Colour Weights per square metre (kgs)	Binding Bar Weight (based on 2 x 1m) (kgs)	
			clear span (mm)																
				300	450	600	750	900	1050	1200	1350	1500	1650	1800	1950	2100			
a.890	4.36	20 x 3	kN/m2	79.0	35.0	18.2	9.30											26.85	0.86
b.890	4.36		D (mm)	0.81	1.82	3.00	3.75												
c.800	3.90																		
a.1240	6.11	25 x 3	kN/m2	124	55.0	31.0	18.2	10.5	6.60	4.40								29.60	1.08
b.1150	5.69		D (mm)	0.65	1.47	2.61	3.75	4.50	5.25	6.00									
c.1000	4.88																		
a.1560	7.08	30 x 3	kN/m2	179	79.0	44.0	28.5	18.2	11.5	7.65	5.38	3.93						32.35	1.30
b.1385	6.92		D (mm)	0.55	1.22	2.15	3.35	4.50	5.25	6.00	6.75	7.50							
c.1200	5.85																		
a.1910	9.46	35 x 3	kN/m2	244	108	61.0	38.9	27.0	18.2	12.2	8.56	6.25	4.69					34.85	1.50
b.1615	8.06		D (mm)	0.47	1.05	1.87	2.92	4.19	5.25	6.00	6.75	7.50	8.25						
c.1410	7.03																		
a.2140	10.0	40 x 3	kN/m2	319	141	79.7	50.9	35.2	25.8	18.2	12.8	9.32	7.0	5.39	4.24			37.60	1.94
b.1845	9.20		D (mm)	0.41	0.92	1.64	2.56	3.67	5.00	6.00	6.75	7.50	8.25	9.00	9.75				
c.1610	8.00																		

max clear span for pedestrian loadings (mm)	def (mm)	L.B.B. size (mm)	'W' load bars at 41mm centres														Self Colour Weights per square metre (kgs)	Binding Bar Weight (based on 2 x 1m) (kgs)	
			clear span (mm)																
				300	450	600	750	900	1050	1200	1350	1500	1650	1800	1950	2100			
a.1150	5.70	20 x 5	kN/m2	133	59.0	30.3	15.5	8.90	5.60									34.85	1.50
b.1090	5.38		D (mm)	0.82	1.84	3.00	3.75	4.50	5.25										
c.950	4.66																		
a.1540	7.06	25 x 5	kN/m2	206	92.0	51.0	30.0	17.5	11.05	7.40	5.20	3.79						39.35	1.86
b.1360	6.68		D (mm)	0.04	0.16	0.40	0.79	4.50	5.25	6.00	6.75	7.50							
c.1190	5.87																		
a.1940	9.60	30 x 5	kN/m2	299	132	74.5	47.5	30.3	19.1	12.8	8.98	6.56	4.92	3.79				44.10	2.24
b.1640	8.17		D (mm)	0.55	1.22	2.18	3.39	4.50	5.25	6.00	6.75	7.50	8.25	9.00					
c.1430	7.08																		
a.2200	10.0	35 x 5	kN/m2	407	181	101	64.9	44.9	30.3	20.3	14.3	10.4	7.82	6.02	4.74			48.85	2.60
b.1915	9.56		D (mm)	0.47	1.06	1.86	2.92	4.19	5.24	6.00	6.75	7.50	8.25	9.00	9.75				
c.1670	8.30																		
a.2310	10.0	40 x 5	kN/m2	532	236	132	84.0	58.0	43.0	30.3	21.3	15.5	11.7	8.99	7.07	5.39		53.35	2.98
b.2140	10.0		D (mm)	0.41	0.92	1.63	2.53	3.63	5.00	6.00	6.75	7.50	8.25	9.00	9.75	10.0			
c.1910	9.51																		
a.2550	10.0	45 x 5	kN/m2	670	299	168	107	74.5	54.6	41.7	30.3	22.1	16.7	12.8	10.1	7.68		58.10	3.36
b.2335	10.0		D (mm)	0.36	0.82	1.46	2.27	3.27	4.44	5.79	6.75	7.50	8.25	9.00	9.75	10.0			
c.2110	10.0																		
a.2790	10.0	50 x 5	kN/m2	830	409	207	132	92.0	67.5	51.5	40.6	30.3	22.8	17.6	13.8	10.5		62.60	3.72
b.2530	10.0		D (mm)	0.33	0.61	1.31	2.04	2.94	4.00	5.21	6.58	7.50	8.25	9.00	9.75	10.0			
c.2280	10.0																		
a.3260	10.0	60 x 5	kN/m2	1199	530	299	191	132	97.3	74.3	58.6	47.3	39.0	30.4	23.9	18.2		72.10	4.48
b.2900	10.0		D (mm)	0.27	0.61	1.09	1.71	2.44	3.34	4.35	5.49	6.76	8.17	9.00	9.75	10.0			
c.2620	10.0																		

Safe uniformly distributed loads (U.D.L.) in kilonewtons per square metre on simply supported panels with deflections (θ) in mm. Based on a working stress of 180 N/mm². Loads shown in the white area have been reduced to keep the deflections within 1/200th of the clear span or 10mm whichever is the lesser. **Please contact Lionweld Kennedy sales team for Serrated Load Tables.**

a – Light Duty 3 kN/m² described as access limited to one person only

b – General Duty 5 kN/m² described as regular two way pedestrian traffic

c – Heavy Duty 7.5 kN/m² described as high density pedestrian traffic

Load Table Designs allow for a 1kN load over a 300mm x 300mm area in accordance with BS 4592-0:2006

Weights shown are for transverse bars at 100mm centres. For 50mm centres add 2.4kg per M²

safety grating - type N plain

max clear span for pedestrian loadings (mm)	def (mm)	L.B.B. size (mm)	'N' load bars at 30mm centres														Self Colour Weights per square metre (kgs)	Binding Bar Weight (based on 2 x 1m) (kgs)	
			clear span (mm)																
				300	450	600	750	900	1050	1200	1350	1500	1650	1800	1950	2100			
a.1050	3.41	20 x 3	kN/m ²	108	48.0	24.7	12.6	7.3										36.06	0.86
b.1020	5.06		D (mm)	0.82	1.84	2.99	3.72	4.47											
c. 890	4.40		D (mm)	0.82	1.84	2.99	3.72	4.47											
a.1450	6.34	25 x 3	kN/m ²	169	75.0	42.0	24.7	14.3	9.01	6.05	4.24							39.50	1.08
b.1275	6.32		D (mm)	0.65	1.47	2.60	3.74	4.49	5.25	6.00	6.75								
c.1110	5.45		D (mm)	0.65	1.47	2.60	3.74	4.49	5.25	6.00	6.75								
a.1815	9.01	30 x 3	kN/m ²	243	108	60.7	38.5	24.7	15.6	10.5	7.34	5.35	4.02					43.24	1.30
b.1535	7.68		D (mm)	0.54	1.23	2.18	3.37	4.50	5.25	6.00	6.75	7.50	8.25						
c.1340	6.69		D (mm)	0.54	1.23	2.18	3.37	4.50	5.25	6.00	6.75	7.50	8.25	9.00	9.75				
a.1980	9.90	35 x 3	kN/m ²	332	147	82.9	53.0	36.7	24.8	16.6	11.7	8.50	6.38	4.91	3.86			46.64	1.50
b.1790	8.95		D (mm)	0.47	1.05	1.87	2.92	4.20	5.25	6.00	6.75	7.50	8.25	9.00	9.75				
c.1560	7.74		D (mm)	0.47	1.05	1.87	2.92	4.20	5.25	6.00	6.75	7.50	8.25	9.00	9.75				
a.2190	10.0	40 x 3	kN/m ²	434	193	108	69.0	48.0	35.0	24.8	17.4	12.7	9.53	7.34	5.77	4.40		50.38	1.72
b.2030	9.91		D (mm)	0.41	0.92	1.63	2.55	3.68	4.97	6.00	6.75	7.50	8.25	9.00	9.75	10.0			
c.1780	8.79		D (mm)	0.41	0.92	1.63	2.55	3.68	4.97	6.00	6.75	7.50	8.25	9.00	9.75	10.0			

max clear span for pedestrian loadings (mm)	def (mm)	L.B.B. size (mm)	'N' load bars at 30mm centres														Self Colour Weights per square metre (kgs)	Binding Bar Weight (based on 2 x 1m) (kgs)	
			clear span (mm)																
				300	450	600	750	900	1050	1200	1350	1500	1650	1800	1950	2100			
a.1350	5.58	20 x 5	kN/m ²	181	80.0	41.3	21.1	12.2	7.70	5.10								46.64	1.50
b.1210	6.01		D (mm)	0.82	1.84	3.00	3.75	4.49	5.25	6.00									
c.1055	5.21		D (mm)	0.82	1.84	3.00	3.75	4.49	5.25	6.00									
a.1790	8.84	25 x 5	kN/m ²	282	125	70.0	41.2	23.9	15.1	10.1	7.08	5.16	3.88					52.80	1.86
b.1510	7.46		D (mm)	0.66	1.47	2.60	3.74	4.50	5.25	6.00	6.75	7.50	8.25						
c.1320	6.53		D (mm)	0.66	1.47	2.60	3.74	4.50	5.25	6.00	6.75	7.50	8.25	9.00	9.75				
a.2010	10.0	30 x 5	kN/m ²	405	180	101	64.5	41.3	26.0	17.4	12.2	8.92	6.70	5.16	4.60			59.22	2.24
b.1815	9.01		D (mm)	0.54	1.23	2.17	3.39	4.50	5.25	6.00	6.75	7.50	8.25	9.00	9.75				
c.1580	7.76		D (mm)	0.54	1.23	2.17	3.39	4.50	5.25	6.00	6.75	7.50	8.25	9.00	9.75				
a.2260	10.0	35 x 5	kN/m ²	554	246	138	88.3	61.2	41.3	27.7	19.4	14.2	10.6	8.19	6.44	4.91		65.34	2.60
b.2090	10.0		D (mm)	0.47	1.05	1.87	2.92	4.20	5.25	6.00	6.75	7.50	8.25	9.00	9.75	10.0			
c.1850	9.19		D (mm)	0.47	1.05	1.87	2.92	4.20	5.25	6.00	6.75	7.50	8.25	9.00	9.75	10.0			
a.2520	10.0	40 x 5	kN/m ²	722	311	180	115	80.0	58.6	41.3	29.0	21.1	15.9	12.2	9.62	7.33		71.80	2.98
b.2310	10.0		D (mm)	0.41	0.89	1.63	2.55	3.68	4.99	6.00	6.75	7.50	8.25	9.00	9.75	10.0			
c.2080	9.83		D (mm)	0.41	0.89	1.63	2.55	3.68	4.99	6.00	6.75	7.50	8.25	9.00	9.75	10.0			
a.2790	10.0	45 x 5	kN/m ²	917	405	228	146	101	74.0	55.0	41.3	30.1	22.6	17.4	13.7	10.5		78.26	3.36
b.2525	10.0		D (mm)	0.37	0.82	1.45	2.27	3.26	4.43	5.61	6.75	7.50	8.25	9.00	9.75	10.0			
c.2280	10.0		D (mm)	0.37	0.82	1.45	2.27	3.26	4.43	5.61	6.75	7.50	8.25	9.00	9.75	10.0			
a.3050	10.0	50 x 5	kN/m ²	1130	503	282	180	125	91.0	70.0	55.2	41.2	31.0	23.9	18.8	14.3		84.38	3.72
b.2730	10.0		D (mm)	0.33	0.74	1.31	2.04	2.94	3.97	5.21	6.58	7.50	8.25	9.00	9.75	10.0			
c.2760	10.0		D (mm)	0.33	0.74	1.31	2.04	2.94	3.97	5.21	6.58	7.50	8.25	9.00	9.75	10.0			
a.3550	10.0	60 x 5	kN/m ²	1630	718	407	260	180	132	101	79.5	64.4	53.1	41.3	32.5	24.8		97.30	4.48
b.3130	10.0		D (mm)	0.27	0.61	1.09	1.71	2.46	3.34	4.35	5.48	6.77	8.17	9.00	9.75	10.0			
c.2830	10.0		D (mm)	0.27	0.61	1.09	1.71	2.46	3.34	4.35	5.48	6.77	8.17	9.00	9.75	10.0			

Safe uniformly distributed loads (U.D.L.) in kilonewtons per square metre on simply supported panels with deflections (δ) in mm. Based on a working stress of 180 N/mm². Loads shown in the white area have been reduced to keep the deflections within 1/200th of the clear span or 10mm whichever is the lesser. **Please contact Lionweld Kennedy sales team for Serrated Load Tables.**

a – Light Duty 3 kN/m² described as access limited to one person only

b – General Duty 5 kN/m² described as regular two way pedestrian traffic

c – Heavy Duty 7.5 kN/m² described as high density pedestrian traffic

Load Table Designs allow for a 1kN load over a 300mm x 300mm area in accordance with BS 4592-0:2006

Weights shown are for transverse bars at 100mm centres. For 50mm centres add 2.4kg per M²

safegrate

Lionweld Kennedy Safegrate is a heavy duty flooring capable of withstanding vehicular loadings.

Load bearing bars are held upright at regular spaced intervals by 9mm dia transverse bars that pass through the flooring. The transverse bars are then spot welded on one side.

This design provides a high lateral restraint and prevents the bearing bars from flipping over due to braking or acceleration forces the grating may be subjected to.

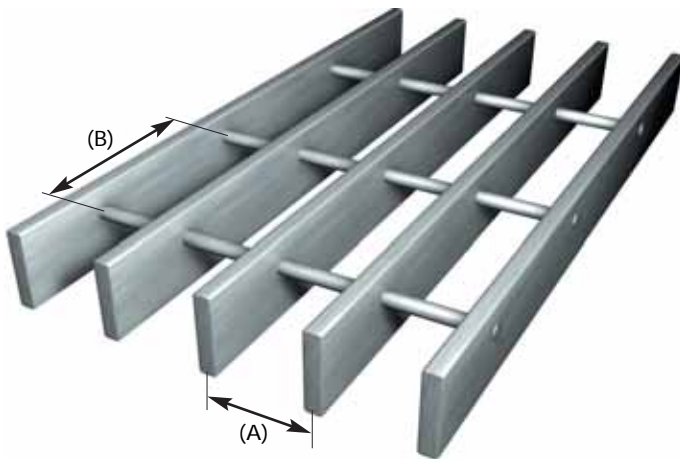

Safegrate		
Load Bearing bar centres (A)	Transverse bar centres (B)	Load Bearing bar thickness available
20, 25, 33, 40 (mm)	100 (mm)	5, 6, 8, 10 (mm)
Load Bearing Bars are available from 25 - 100mm deep		
Surfaces Available <small>see page 06</small>		
Plain		
Rolled Serrated		
Machine Serrated <small>(up to 6mm thick)</small>		

Fixings Recommended for Safegrate flooring:

Removable Fixing

- Saddle Clip
- Narrow Clip (20mm centres only)
- Universal Deep Saddle Clip

Positive Fixing

- Fixing pads
- Deep Saddle with self tapping bolt

see page 28 for further details



safegrate - safe wheel loads

The following load tables have been devised to help specify the correct Safegrate for various types of vehicle.

Common tread contact areas have been assumed for each vehicle type to allow an easy selection.

Lionweld Kennedy can also help to specify Safegrate for alternative tread contact areas or site specific applications but in order to do so the following information is required.

- Maximum wheel load
- Maximum clear span
- Length and Breadth of the tread contact area
- Any restrictions on the depth of grating

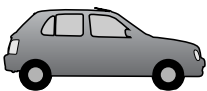

cars

load bearing bar size	Load bearing bars at 40mm centres permissible loads (tonnes) for car wheels with contact area of 165mm x 165mm													Self Colour Weights per square metre (kgs)	Binding Bar Weight (based on 2 x 1m) (kgs)
	clear span (mm)														
	300	450	600	750	900	1050	1200	1350	1500	1650	1800	1950	2100		
mm	300	450	600	750	900	1050	1200	1350	1500	1650	1800	1950	2100		
40 x 5	1.94	1.15	0.82	0.63	0.52	0.44	0.38	0.33	0.29	0.24	0.20	0.17	0.14	42.44	3.140
50 x 5	3.03	1.80	1.28	0.99	0.81	0.68	0.59	0.52	0.47	0.42	0.38	0.34	0.28	62.58	3.920
60 x 5	4.37	2.59	1.84	1.42	1.16	0.98	0.85	0.75	0.67	0.61	0.55	0.51	0.47	62.98	4.720
70 x 5	5.95	3.52	2.50	1.94	1.58	1.34	1.16	1.02	0.91	0.83	0.75	0.69	0.64	73.12	5.500
75 x 5	6.83	4.04	2.87	2.22	1.82	1.53	1.33	1.17	1.05	0.95	0.86	0.80	0.74	78.32	5.900
80 x 5	7.77	4.60	3.26	2.53	2.07	1.75	1.51	1.33	1.19	1.08	0.98	0.90	0.84	83.26	6.280
90 x 5	9.83	5.82	4.13	3.20	2.62	2.21	1.91	1.69	1.51	1.36	1.25	1.15	1.06	93.53	7.070
100 x 5	12.1	7.18	5.10	3.96	3.23	2.73	2.36	2.08	1.86	1.68	1.54	1.41	1.31	103.80	7.860

safegrate - safe wheel loads

light vans and trucks

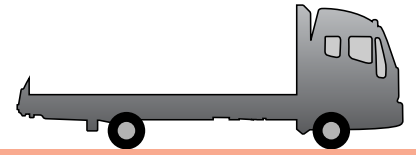

load bearing bar size	Load bearing bars at 40mm centres permissible loads (tonnes) for light van wheels with contact area of 220mm x 220mm													Self Colour Weights per square metre (kgs)	Binding Bar Weight (based on 2 x 1m) (kgs)
	clear span (mm)														
	mm	300	450	600	750	900	1050	1200	1350	1500	1650	1800	1950		
40 x 6	3.20	1.79	1.24	0.95	0.77	0.65	0.56	0.49	0.42	0.35	0.29	0.25	0.21	50.50	3.760
50 x 6	5.00	2.80	1.94	1.49	1.20	1.01	0.87	0.77	0.68	0.62	0.56	0.49	0.40	62.98	4.720
60 x 6	7.20	4.03	2.79	2.14	1.73	1.46	1.26	1.10	0.99	0.89	0.81	0.74	0.69	75.20	5.660
70 x 6	9.80	5.48	3.80	2.91	2.36	1.99	1.71	1.50	1.34	1.21	1.10	1.01	0.94	87.42	6.600
75 x 6	11.3	6.29	4.36	3.34	2.71	2.28	1.96	1.73	1.54	1.39	1.27	1.16	1.08	93.27	7.060
80 x 6	12.8	7.16	4.97	3.80	3.08	2.59	2.23	1.96	1.75	1.58	1.44	1.32	1.22	99.64	7.540
90 x 6	16.2	9.06	6.28	4.81	3.90	3.28	2.83	2.48	2.22	2.00	1.82	1.67	1.55	111.00	8.480
100 x 6	20.0	11.2	7.76	5.94	4.81	4.04	3.49	3.07	2.74	2.47	2.25	2.07	1.91	124.08	9.420

load bearing bar size	Table to show maximum wheel loads (tonnes) Load bearing bars at 40mm centres permissible loads (tonnes) for light van wheels with contact area of 220mm x 220mm													Self Colour Weights per square metre (kgs)	Binding Bar Weight (based on 2 x 1m) (kgs)
	clear span (mm)														
	mm	300	450	600	750	900	1050	1200	1350	1500	1650	1800	1950		
40 x 8	4.27	2.39	1.66	1.27	1.03	0.86	0.74	0.65	0.57	0.47	0.39	0.33	0.27	67.90	5.020
50 x 8	6.67	3.73	2.59	1.98	1.60	1.35	1.16	1.02	0.91	0.82	0.75	0.65	0.53	83.26	6.280
60 x 8	9.60	5.37	3.72	2.85	2.31	1.94	1.67	1.47	1.31	1.19	1.08	0.99	0.92	99.64	7.540
70 x 8	13.1	7.31	5.07	3.88	3.14	2.64	2.28	2.00	1.79	1.61	1.47	1.35	1.25	116.02	8.800
75 x 8	15.0	8.39	5.82	4.46	3.61	3.03	2.62	2.30	2.05	1.85	1.69	1.55	1.43	124.08	9.420
80 x 8	17.1	9.54	6.62	5.07	4.11	3.45	2.98	2.62	2.33	2.11	1.92	1.76	1.63	132.14	10.04
90 x 8	21.6	12.1	8.38	6.42	5.20	4.37	3.77	3.31	2.95	2.67	2.43	2.23	2.06	148.52	11.30
100 x 8	26.7	14.9	10.3	7.92	6.42	5.39	4.65	4.09	3.65	3.29	3.00	2.76	2.55	164.90	12.56

HGV non-driving wheels

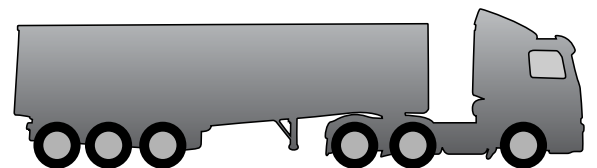

load bearing bar size	Load bearing bars at 40mm centres permissible loads (tonnes) for large truck double wheel base with contact area of 220mm x 220mm													Self Colour Weights per square metre (kgs)	Binding Bar Weight (based on 2 x 1m) (kgs)
	clear span (mm)														
	mm	300	450	600	750	900	1050	1200	1350	1500	1650	1800	1950		
40 x 10	5.34	2.98	2.07	1.58	1.28	1.08	0.93	0.82	0.71	0.58	0.49	0.42	0.34	83.60	6.280
50 x 10	8.34	4.66	3.23	2.48	2.01	1.69	1.45	1.28	1.14	1.03	0.94	0.81	0.67	103.80	7.860
60 x 10	12.01	6.71	4.66	3.56	2.89	2.43	2.09	1.84	1.64	1.48	1.35	1.24	1.15	124.08	9.420
70 x 10	16.34	9.13	6.34	4.85	3.93	3.30	2.85	2.50	2.23	2.02	1.84	1.69	1.56	144.62	11.00
75 x 10	18.76	10.48	7.27	5.57	4.51	3.79	3.27	2.87	2.56	2.31	2.11	1.94	1.79	155.02	11.80
80 x 10	21.34	11.93	8.28	6.34	5.13	4.31	3.72	3.27	2.92	2.63	2.40	2.20	2.04	164.90	12.56
90 x 10	27.01	15.09	10.47	8.02	6.50	5.46	4.71	4.14	3.69	3.33	3.04	2.79	2.58	185.44	14.14
100 x 10	33.35	18.64	12.93	9.90	8.02	6.74	5.81	5.11	4.56	4.11	3.75	3.44	3.18	205.72	15.70

safegrate - safe wheel loads

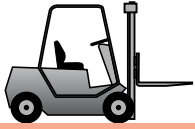

fork lift trucks

load bearing bar size	Load bearing bars at 25mm centres permissible loads (tonnes) for fork lift truck wheels with contact area of 55mm x 150mm													Self Colour Weights per square metre (kgs)	Binding Bar Weight (based on 2 x 1m) (kgs)
	clear span (mm)														
mm	300	450	600	750	900	1050	1200	1350	1500	1650	1800	1950	2100		
40 x 8	1.80	1.08	0.77	0.60	0.49	0.42	0.36	0.32	0.28	0.23	0.20	0.17	0.14	103.06	5.020
50 x 8	2.82	1.69	1.21	0.94	0.77	0.65	0.56	0.50	0.44	0.40	0.37	0.32	0.27	130.36	6.280
60 x 8	4.06	2.43	1.74	1.35	1.11	0.94	0.81	0.72	0.64	0.58	0.53	0.49	0.45	156.19	7.540
70 x 8	5.52	3.31	2.37	1.84	1.51	1.27	1.10	0.97	0.87	0.79	0.72	0.66	0.61	182.02	8.880
75 x 8	6.34	3.80	2.72	2.11	1.73	1.46	1.27	1.12	1.00	0.91	0.83	0.76	0.70	194.73	9.420
80 x 8	7.21	4.33	3.09	2.40	1.97	1.66	0.44	1.27	1.14	1.03	0.94	0.87	0.80	207.44	10.04
90 x 8	9.12	5.47	3.91	3.04	2.49	2.11	1.82	1.61	1.44	1.30	1.19	1.09	1.01	233.44	11.30
100 x 8	11.3	6.76	4.83	3.75	3.07	2.60	2.25	1.99	1.78	1.61	1.47	1.35	1.25	259.10	12.56

load bearing bar size	Load bearing bars at 25mm centres permissible loads (tonnes) for fork lift truck wheels with contact area of 55mm x 150mm													Self Colour Weights per square metre (kgs)	Binding Bar Weight (based on 2 x 1m) (kgs)
	clear span (mm)														
mm	300	450	600	750	900	1050	1200	1350	1500	1650	1800	1950	2100		
40 x 10	2.25	1.35	0.97	0.75	0.61	0.52	0.45	0.40	0.35	0.29	0.24	0.21	0.17	127.56	6.280
50 x 10	3.52	2.11	1.51	1.17	0.96	0.81	0.70	0.62	0.56	0.50	0.46	0.41	0.33	162.75	7.860
60 x 10	5.07	3.04	2.17	1.69	1.38	1.17	1.01	0.89	0.80	0.72	0.66	0.61	0.56	194.73	9.420
70 x 10	6.90	4.14	2.96	2.30	1.88	1.59	1.38	1.22	1.09	0.99	0.90	0.83	0.77	227.13	11.00
75 x 10	7.92	4.75	3.39	2.64	2.16	1.83	1.58	1.40	1.25	1.13	1.03	0.95	0.88	243.52	11.80
80 x 10	9.01	5.41	3.86	3.00	2.46	2.08	1.80	1.59	1.42	1.29	1.18	1.08	1.00	259.10	12.56
90 x 10	11.4	6.84	4.89	3.80	3.11	2.63	2.28	2.01	1.80	1.63	1.49	1.37	1.27	291.49	14.14
100 x 10	14.1	8.45	6.03	4.69	3.84	3.25	2.82	2.48	2.22	2.01	1.84	1.69	1.56	323.41	15.70

load bearing bar size	Load bearing Bars at 33mm centres permissible loads (tonnes) for fork lift truck wheels with contact area of 100mm x 250mm													Self Colour Weights per square metre (kgs)	Binding Bar Weight (based on 2 x 1m) (kgs)
	clear span (mm)														
mm	300	450	600	750	900	1050	1200	1350	1500	1650	1800	1950	2100		
40 x 10	3.86	2.08	1.42	1.08	0.87	0.73	0.63	0.55	0.47	0.39	0.33	0.28	0.23	99.30	6.280
50 x 10	6.03	3.25	2.22	1.69	1.36	1.14	0.98	0.86	0.77	0.69	0.63	0.54	0.45	124.65	7.860
60 x 10	8.69	4.68	3.20	2.43	1.96	1.64	1.41	1.24	1.11	1.00	0.91	0.83	0.77	149.06	9.420
70 x 10	11.8	6.37	4.36	3.31	2.67	2.24	1.93	1.69	1.51	1.36	1.24	1.13	1.05	173.79	11.00
75 x 10	13.6	7.31	5.00	3.80	3.07	2.57	2.21	1.94	1.73	1.56	1.42	1.30	1.20	186.31	11.80
80 x 10	15.5	8.32	5.69	4.33	3.49	2.92	2.51	2.21	1.97	1.77	1.61	1.48	1.37	198.21	12.56
90 x 10	19.6	10.5	7.20	5.47	4.41	3.70	3.18	2.79	2.49	2.24	2.04	1.87	1.73	222.94	14.14
100 x 10	24.1	13.0	8.89	6.76	5.45	4.57	3.93	3.45	3.07	2.77	2.52	2.31	2.14	205.72	15.70

safelock

Double serrated Safelock is the most slip resistant flooring in the Lionweld Kennedy range.

Upright load bearing bars are fixed at regular spaced intervals by 13mm x 13mm x 3mm inverted angles, pressure locked into the bearing bars.

Commonly used in extreme conditions such as offshore applications or areas where lubricants are regularly used.

Safelock is usually supplied with a double serrated finish to provide optimum slip resistance. Other surfaces available on request.

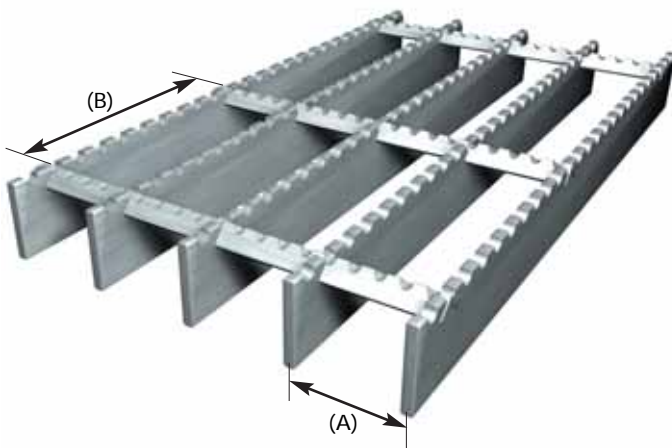

Safelock	
Load Bearing bar centres (A)	Transverse bar centres (B)
N (30mm)	100 (mm)
W (41mm)	
Load Bearing Bars range from 25mm - 50mm deep	
Surfaces Available <small>see page 06</small>	
Plain	
Double Serrated	

Fixings Recommended for Safelock flooring:

Removable Fixing

- Saddle Clip
- Universal Deep Saddle Clip

Positive Fixing

- Deep Saddle with self tapping bolt
- Fixing pads

see page 28 for further details

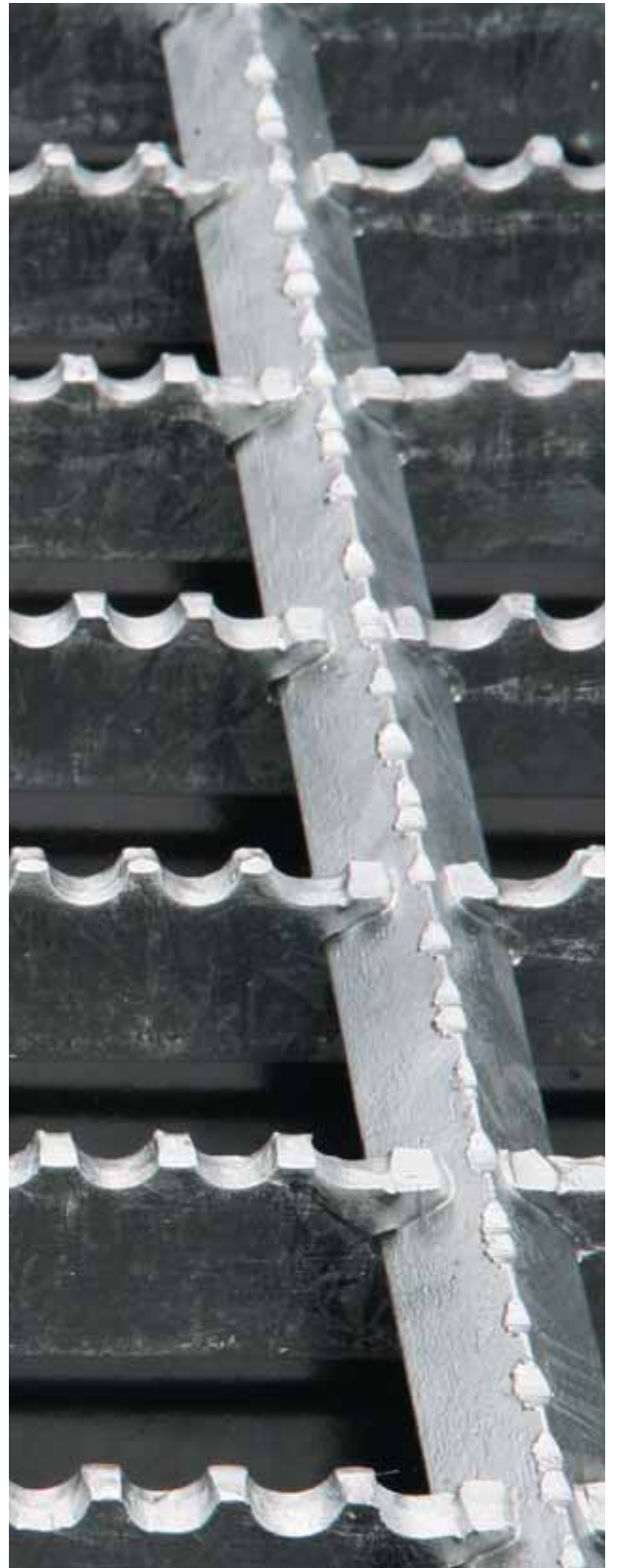

safelock – type W plain

max clear span for pedestrian loadings (mm)	def (mm)	L.B.B. size (mm)	'W' load bars at 41mm centres														Self Colour Weights per square metre (kgs)	Binding Bar Weight (based on 2 x 1m) (kgs)	
			clear span (mm)																
				300	450	600	750	900	1050	1200	1350	1500	1650	1800	1950	2100			
a. 848	4.2	25 x 3	kN/m ²	29.79	13.24	7.45	4.34											16.16	1.178
b. 716	3.6		D (mm)	0.66	1.48	2.63	3.75												
c. 598	2.6																		
a. 1122	5.6	30 x 3	kN/m ²	57.43	25.53	14.36	9.19	5.81	3.66									18.91	1.413
b. 946	4.7		D (mm)	0.55	1.23	2.20	3.43	4.50	5.25										
c. 827	4.1																		
a. 1396	7.0	35 x 3	kN/m ²	94.75	42.11	23.69	15.16	10.53	7.05	4.72	3.32							21.41	1.640
b. 1177	5.9		D (mm)	0.47	1.06	1.88	2.94	4.23	5.25	6.00	6.75								
c. 1028	5.1																		
a. 1669	8.3	40 x 3	kN/m ²	141.86	63.05	35.47	22.70	15.76	11.58	8.08	5.67	4.14	3.11					24.16	1.884
b. 1408	7.0		D (mm)	0.41	0.93	1.65	2.57	3.70	5.04	6.00	6.75	7.50	8.25						
c. 1230	6.2																		

max clear span for pedestrian loadings (mm)	def (mm)	L.B.B. size (mm)	'W' load bars at 41mm centres														Self Colour Weights per square metre (kgs)	Binding Bar Weight (based on 2 x 1m) (kgs)	
			clear span (mm)																
				300	450	600	750	900	1050	1200	1350	1500	1650	1800	1950	2100			
a. 1006	5.0	25 x 5	kN/m ²	49.65	22.07	12.41	7.24	4.19										25.91	1.963
b. 848	4.2		D (mm)	0.66	1.48	2.63	3.75	4.50											
c. 741	3.7																		
a. 1330	6.7	30 x 5	kN/m ²	95.72	42.54	23.93	15.32	9.69	6.10	4.09								30.66	2.355
b. 1122	5.6		D (mm)	0.55	1.23	2.20	3.43	4.50	5.25	6.00									
c. 980	4.9																		
a. 1655	8.3	35 x 5	kN/m ²	157.92	70.19	39.48	25.27	17.55	11.75	7.87	5.53	4.03	3.03					35.41	2.748
b. 1396	7.0		D (mm)	0.47	1.06	1.88	2.94	4.23	5.25	6.00	6.75	7.50	8.25						
c. 1219	6.1																		
a. 1979	9.9	40 x 5	kN/m ²	236.44	105.08	59.11	37.83	26.27	19.30	13.46	9.46	6.89	5.18	3.99	3.14			39.91	3.140
b. 1669	8.3		D (mm)	0.41	0.93	1.65	2.57	3.70	5.04	6.00	6.75	7.50	8.25	9.00	9.75				
c. 1458	7.3																		
a. 2224	10.0	45 x 5	kN/m ²	331.40	147.29	82.85	53.02	36.82	27.05	20.71	14.91	10.87	8.17	6.29	4.95	3.77		44.66	3.533
b. 1943	9.7		D (mm)	0.37	0.82	1.46	2.29	3.29	4.48	5.85	6.75	7.50	8.25	9.00	9.75	10.0			
c. 1698	8.5																		
a. 2455	10.0	50 x 5	kN/m ²	442.87	196.83	110.72	70.86	49.21	36.15	27.68	21.87	16.14	12.13	9.34	7.35	5.60		49.16	3.925
b. 2161	10.0		D (mm)	0.33	0.74	1.32	2.06	2.96	4.03	5.27	6.67	7.50	8.25	9.00	9.75	10.0			
c. 1937	9.7																		

Safe uniformly distributed loads (U.D.L.) in kilonewtons per square metre on simply supported panels with deflections (δ) in mm. Based on a working stress of 180 N/mm². Loads shown in the white area have been reduced to keep the deflections within 1/200th of the clear span or 10mm whichever is the lesser. **Please contact Lionweld Kennedy sales team for Serrated Load Tables.**

a – Light Duty 3 kN/m² described as access limited to one person only

b – General Duty 5 kN/m² described as regular two way pedestrian traffic

c – Heavy Duty 7.5 kN/m² described as high density pedestrian traffic

Load Table Designs allow for a 1kN load over a 300mm x 300mm area in accordance with BS 4592-0:2006
Weights shown are for transverse bars at 100mm centres. For 50mm centres add 5.8kg per M²

safelock – type N plain

max clear span for pedestrian loadings (mm)	def (mm)	L.B.B. size (mm)	'N' load bars at 30mm centres														Self Colour Weights per square metre (kgs)	Binding Bar Weight (based on 2 x 1m) (kgs)	
			clear span (mm)																
				300	450	600	750	900	1050	1200	1350	1500	1650	1800	1950	2100			
a. 940	4.7	25 x 3	kN/m2	40.52	18.01	10.13	5.91	3.42										21.02	1.178
b. 793	4.0		D (mm)	0.66	1.48	2.63	3.75	4.50											
c. 693	3.5																		
a. 1243	6.2	30 x 3	kN/m2	78.11	34.72	19.53	12.50	7.91	4.98	3.34								24.76	1.413
b. 1049	5.2		D (mm)	0.55	1.23	2.20	3.43	4.50	5.25	6.00									
c. 916	4.6																		
a. 1546	7.7	35 x 3	kN/m2	128.86	57.27	32.22	20.62	14.32	9.58	6.42	4.51	3.29						28.16	1.640
b. 1304	6.5		D (mm)	0.47	1.06	1.88	2.94	4.23	5.25	6.00	6.75	7.50							
c. 1139	5.7																		
a. 1850	9.2	40 x 3	kN/m2	192.93	85.75	48.23	30.87	21.44	15.75	10.99	7.72	5.63	4.23	3.26				31.90	1.884
b. 1560	7.8		D (mm)	0.41	0.93	1.65	2.57	3.70	5.04	6.00	6.75	7.50	8.25	9.00					
c. 1363	6.8																		

max clear span for pedestrian loadings (mm)	def (mm)	L.B.B. size (mm)	'N' load bars at 30mm centres														Self Colour Weights per square metre (kgs)	Binding Bar Weight (based on 2 x 1m) (kgs)	
			clear span (mm)																
				300	450	600	750	900	1050	1200	1350	1500	1650	1800	1950	2100			
a. 1114	5.6	25 x 5	kN/m2	67.53	30.01	16.88	9.84	5.70	3.59									34.32	1.963
b. 940	4.7		D (mm)	0.66	1.48	2.63	3.75	4.50	5.25										
c. 821	4.1																		
a. 1474	7.4	30 x 5	kN/m2	130.18	57.86	32.55	20.83	13.18	8.30	5.56	3.90							40.74	2.355
b. 1243	6.2		D (mm)	0.55	1.23	2.20	3.43	4.50	5.25	6.00	6.75								
c. 1086	5.4																		
a. 1834	9.2	35 x 5	kN/m2	214.77	95.45	53.69	34.36	23.86	15.97	10.70	7.52	5.48	4.12	3.17				46.86	2.748
b. 1546	7.7		D (mm)	0.47	1.06	1.88	2.94	4.23	5.25	6.00	6.75	7.50	8.25	9.00					
c. 1351	6.8																		
a. 2143	10.0	40 x 5	kN/m2	321.56	142.91	80.39	51.45	35.73	26.25	18.31	12.86	9.38	7.04	5.43	4.27	3.25		53.32	3.140
b. 1850	9.2		D (mm)	0.41	0.93	1.65	2.57	3.70	5.04	6.00	6.75	7.50	8.25	9.00	9.75	10.0			
c. 1616	8.1																		
a. 2402	10.0	45 x 5	kN/m2	450.70	200.31	112.68	72.11	50.08	36.79	28.17	20.28	14.78	11.11	8.56	6.73	5.13		59.78	3.533
b. 2114	10.0		D (mm)	0.37	0.82	1.46	2.29	3.29	4.48	5.85	6.75	7.50	8.25	9.00	9.75	10.0			
c. 1881	9.4																		
a. 2651	10.0	50 x 5	kN/m2	602.30	267.69	150.57	96.37	66.92	49.17	37.64	29.74	21.95	16.49	12.70	9.99	7.62		65.90	3.925
b. 2333	10.0		D (mm)	0.33	0.74	1.32	2.06	2.96	4.03	5.27	6.67	7.50	8.25	9.00	9.75	10.0			
c. 2108	10.0																		

Safe uniformly distributed loads (U.D.L.) in kilonewtons per square metre on simply supported panels with deflections (δ) in mm. Based on a working stress of 180 N/mm². Loads shown in the white area have been reduced to keep the deflections within 1/200th of the clear span or 10mm whichever is the lesser. **Please contact Lionweld Kennedy sales team for Serrated Load Tables.**

a – Light Duty 3 kN/m² described as access limited to one person only

b – General Duty 5 kN/m² described as regular two way pedestrian traffic

c – Heavy Duty 7.5 kN/m² described as high density pedestrian traffic

Load Table Designs allow for a 1kN load over a 300mm x 300mm area in accordance with BS 4592-0:2006

Weights shown are for transverse bars at 100mm centres. For 50mm centres add 5.8kg per M²

Lionweld Kennedy Safetread (Diamond Pattern) is constructed using a series of flat load bearing bars held upright by corrugated bars.

Universally accepted as one of the strongest and most economical open steel gratings, Safetread has been installed in the largest of power stations, steelworks, chemical plants, distilleries and a host of other industrial and civil undertakings where strength, cleanliness, light, ventilation and resistance to corrosion are essential factors.

The corrugated bars not only contribute to the load carrying capabilities of the grating, but also provide the grating with increased lateral restraint. The load bearing bars and corrugated bars are spot welded together at each intersection point.

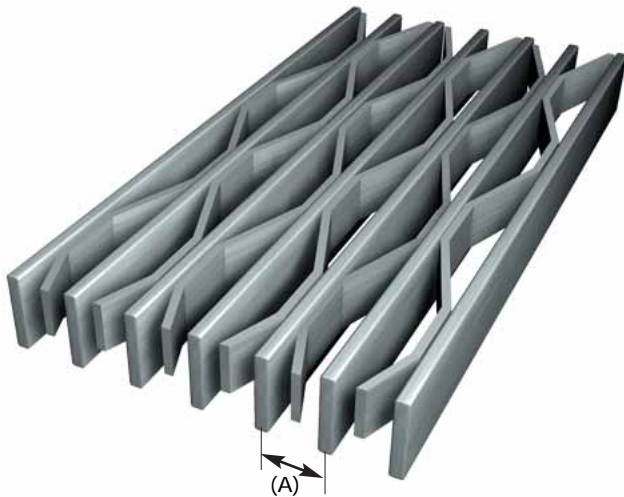

Safetread		
Load Bearing Bar	Pitch (A)	Corrugated Bars
3mm (LSP)	38 (mm)	3 (mm)
5mm (HSP)	40 (mm)	3 (mm)
Corrugated bars generally have 5mm less depth than load bearing bars		
Surfaces Available <small>see page 06</small>		
Plain		
Rolled Serrated (all bars are serrated)		
Machine Serrated (all bars are serrated)		

Fixings Recommended for Safetread flooring:

Removable Fixing

- Diamond clip

Positive Fixing

- Fixing pads

see page 28 for further details

safetread

max clear span for pedestrian loadings (mm)	def (mm)	L.B.B. size (mm)	LSP load bars at 38mm centres														Self Colour Weights per square metre (kgs)	Binding Bar Weight (based on 2 x 1m) (kgs)	
			clear span (mm)																
				300	450	600	750	900	1050	1200	1350	1500	1650	1800	1950	2100			
a. 1236	6.18	20 x 3	kN/m ²	115.2	51.2	26.24	13.43	7.78	4.90	3.28								25.2	0.86
b. 1043	5.21		D (mm)	0.82	1.85	3.00	3.75	4.50	5.25	6.00									
c. 911	4.55																		
a. 1472	7.36	25 x 3	kN/m ²	155.6	69.16	38.9	22.68	13.13	8.23	5.54	3.89							28.3	1.08
b. 1242	6.21		D (mm)	0.66	1.48	2.63	3.75	4.50	5.25	6.00	6.75								
c. 1085	5.42																		
a. 1779	8.89	30 x 3	kN/m ²	228.9	101.7	57.22	36.62	23.17	14.59	9.78	6.87	5.01	3.76					34.6	1.30
b. 1500	7.50		D (mm)	0.55	1.24	2.20	3.43	4.50	5.25	6.00	6.75	7.50	8.25						
c. 1311	6.55																		
a. 2289	10.00	40 x 3	kN/m ²	418.6	186.0	104.6	66.97	46.51	34.17	23.8	16.7	12.2	9.17	7.06	5.56	4.24		47.2	1.88
b. 2015	10.00		D (mm)	0.41	0.93	1.65	2.58	3.70	5.04	6.00	6.75	7.50	8.25	9.00	9.75	10.00			
c. 1764	8.82																		

max clear span for pedestrian loadings (mm)	def (mm)	L.B.B. size (mm)	HSP load bars at 40mm centres														Self Colour Weights per square metre (kgs)	Binding Bar Weight (based on 2 x 1m) (kgs)	
			clear span (mm)																
				300	450	600	750	900	1050	1200	1350	1500	1650	1800	1950	2100			
a. 1391	6.95	20 x 5	kN/m ²	164.1	72.9	37.4	19.1	11.1	6.97	4.67	3.28							32.1	1.50
b. 1173	5.87		D (mm)	0.82	1.85	3.00	3.75	4.50	5.25	6.00	6.75								
c. 1025	5.12																		
a. 1684	8.42	25 x 5	kN/m ²	232.9	103.5	58.2	33.9	19.7	12.4	8.29	5.82	4.24	3.19					37.0	1.86
b. 1420	7.10		D (mm)	0.66	1.48	2.63	3.75	4.50	5.25	6.00	6.75	7.50	8.25						
c. 1241	6.20																		
a. 2022	10.0	30 x 5	kN/m ²	340.00	151.1	85.0	54.4	34.4	21.7	14.5	10.2	7.44	5.59	4.30	3.38			45.0	2.24
b. 1712	8.56		D (mm)	0.55	1.24	2.20	3.43	4.50	5.25	6.00	6.75	7.50	8.25	9.00	9.75				
c. 1496	7.48																		
a. 2521	10.0	40 x 5	kN/m ²	615.7	273.6	153.9	98.5	68.4	50.3	35.1	24.6	17.9	13.5	10.4	8.17	6.23		61.0	2.98
b. 2219	10.0		D (mm)	0.41	0.93	1.65	2.57	3.70	5.04	6.00	6.75	7.50	8.25	9.00	9.75	10.0			
c. 2005	10.0																		
a. 2989	10.0	50 x 5	kN/m ²	973.3	432.6	243.3	155.7	108.1	79.4	60.8	48.1	35.5	26.6	20.5	16.1	12.3		77.0	3.72
b. 2631	10.0		D (mm)	0.33	0.74	1.32	2.06	2.96	4.03	5.27	6.67	7.50	8.25	9.00	9.75	10.0			
c. 2377	10.0																		

Safe uniformly distributed loads (U.D.L.) in kilonewtons per square metre on simply supported panels with deflections (δ) in mm. Based on a working stress of 180 N/mm². Loads shown in the white area have been reduced to keep the deflections within 1/200th of the clear span or 10mm whichever is the lesser. **Please contact Lionweld Kennedy sales team for Serrated Load Tables.**

- a** – Light Duty 3 kN/m² described as access limited to one person only
- b** – General Duty 5 kN/m² described as regular two way pedestrian traffic
- c** – Heavy Duty 7.5 kN/m² described as high density pedestrian traffic

Load Table Designs allow for a 1kN load over a 300mm x 300mm area in accordance with BS 4592-0:2006

Lionweld Kennedy Safedeck closed flooring system comprises of a Safegrid or Safegrate open bar grating sub-structure with a durbar plate welded to the top surface.

Safedeck provides a greater load bearing capacity when compared to open bar grating or plated flooring offered individually. The weight to strength ratio provides a cost efficient solution to a closed flooring requirement.

Safedeck is available as standard with load bearing bars at 41mm centres and transverse bars at 100mm centres. Durbar thickness is usually 3mm.

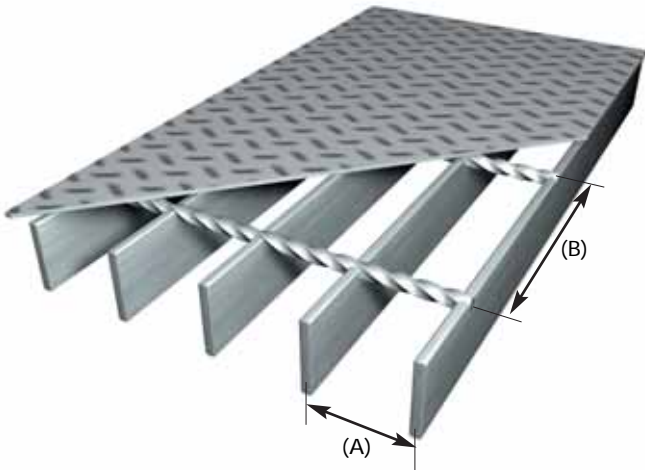

Safedeck with 3mm durbar floorplate

Load Bearing Bar Centres (A)	Transverse Bar Centres (B)
W (41mm)	100 (mm)
N (30mm)	100 (mm)

Fixings Recommended for Safetread flooring:

Positive Fixing

- Fixing pads
- Drilled and Screwed

see page 28 for further details



max clear span for pedestrian loadings (mm)	def (mm)	L.B.B. size (mm)	load bars at 41mm centres with 3mm durbar plate														Self Colour Weights per square metre (kgs)	Binding Bar Weight (based on 2 x 1m) (kgs)
			clear span (mm)															
				300	450	600	750	900	1050	1200	1350	1500	1650	1800	1950	2100		
a. 1692	8.46	20 x 3	kN/m ²	201	89.5	50.3	32.2	19.9	12.5	8.41	5.90	4.30	3.23				37.54	0.86
b. 1427	7.13		D (mm)	0.56	1.26	2.25	3.51	4.50	5.25	6.00	6.75	7.50	8.25					
c. 1246	6.23																	
a. 2034	10.0	25 x 3	kN/m ²	288	128	72.0	46.1	32.0	22.2	14.9	10.4	7.61	5.71	4.40	3.46		40.49	1.08
b. 1725	8.63		D (mm)	0.45	1.02	1.82	2.84	4.09	5.25	6.00	6.75	7.50	8.25	9.00	9.75			
c. 1507	7.53																	
a. 2287	10.0	30 x 3	kN/m ²	389	173	97.3	62.2	43.2	31.8	23.7	16.7	12.2	9.13	7.03	5.53	4.22	43.43	1.30
b. 2013	10.0		D (mm)	0.38	0.86	1.54	2.40	3.46	4.71	6.00	6.75	7.50	8.25	9.00	9.75	10.0		
c. 1762	8.81																	
a. 2526	10.0	35 x 3	kN/m ²	504	224	126	80.6	56.0	41.1	31.5	24.8	18.1	13.6	10.5	8.23	6.28	46.38	1.50
b. 2223	10.0		D (mm)	0.33	0.75	1.34	2.09	3.01	4.09	5.35	6.75	7.50	8.25	9.00	9.75	10.0		
c. 2009	10.0																	
a. 2754	10.0	40 x 3	kN/m ²	632	281	158	101	70.2	51.6	39.5	31.2	25.3	19.2	14.8	11.6	8.87	49.32	1.94
b. 2424	10.0		D (mm)	0.30	0.67	1.19	1.85	2.67	3.63	4.75	6.01	7.42	8.25	9.00	9.75	10.0		
c. 2190	10.0																	

max clear span for pedestrian loadings (mm)	def (mm)	L.B.B. size (mm)	load bars at 41mm centres with 3mm durbar plate														Self Colour Weights per square metre (kgs)	Binding Bar Weight (based on 2 x 1m) (kgs)
			clear span (mm)															
				300	450	600	750	900	1050	1200	1350	1500	1650	1800	1950	2100		
a. 1911	9.55	20 x 5	kN/m ²	321	142	80.1	49.6	28.7	18.1	12.1	8.51	6.20	4.66	3.59			45.39	1.50
b. 1612	8.06		D (mm)	0.62	1.40	2.48	3.75	4.50	5.25	6.00	6.75	7.50	8.25	9.00				
c. 1408	7.04																	
a. 2223	10.0	25 x 5	kN/m ²	455	202	114	72.8	50.2	31.6	21.2	14.9	10.8	8.15	6.28	4.94	3.76	50.30	1.86
b. 1942	9.71		D (mm)	0.50	1.13	2.01	3.15	4.50	5.25	6.00	6.75	7.50	8.25	9.00	9.75	10.0		
c. 1696	8.48																	
a. 2494	10.0	30 x 5	kN/m ²	610	271	153	97.6	67.8	49.8	33.6	23.6	17.2	12.9	9.95	7.83	5.97	55.21	2.24
b. 2195	10.0		D (mm)	0.43	0.96	1.70	2.66	3.83	5.22	6.00	6.75	7.50	8.25	9.00	9.75	10.0		
c. 1978	9.89																	
a. 2751	10.0	35 x 5	kN/m ²	786	349	196	126	87.3	64.1	49.1	34.9	25.5	19.1	14.7	11.6	8.83	60.11	2.60
b. 2421	10.0		D (mm)	0.37	0.83	1.48	2.31	3.33	4.54	5.93	6.75	7.50	8.25	9.00	9.75	10.0		
c. 2188	10.0																	
a. 2996	10.0	40 x 5	kN/m ²	980	436	245	157	109	80.0	61.3	48.4	35.8	26.9	20.7	16.3	12.4	65.02	2.98
b. 2637	10.0		D (mm)	0.33	0.74	1.31	2.05	2.96	4.02	5.26	6.65	7.50	8.25	9.00	9.75	10.0		
c. 2383	10.0																	

Safe uniformly distributed loads (U.D.L.) in kilonewtons per square metre on simply supported panels with deflections (δ) in mm. Based on a working stress of 180 N/mm². Loads shown in the white area have been reduced to keep the deflections within 1/200th of the clear span or 10mm whichever is the lesser.

- a** – Light Duty 3 kN/m² described as access limited to one person only
- b** – General Duty 5 kN/m² described as regular two way pedestrian traffic
- c** – Heavy Duty 7.5 kN/m² described as high density pedestrian traffic

Load Table Designs allow for a 1kN load over a 300mm x 300mm area in accordance with BS 4592-0:2006

Lionweld Kennedy 'Stanweld' open bar grating comprises of specially rolled mild steel 'T' bars with a raised 'pyramid' pattern top.

Stanweld is unique as its load carrying capabilities in relation to depth and weight are superior to those of any type of open steel grating.

This product has been regularly supplied to chemical, petro-chemical and offshore installations. The large surface area provides an excellent feeling of security underfoot.

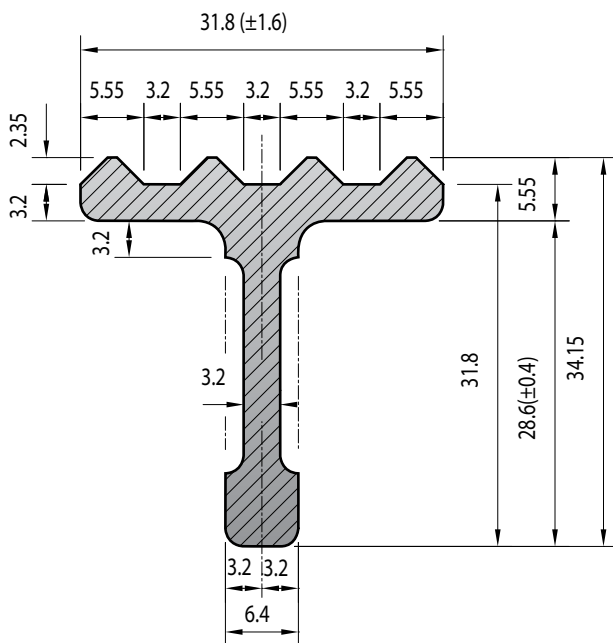

Fixings Recommended for Stanweld flooring:

Positive Fixing

- Fixing pads

see page 28 for further details

stanweld

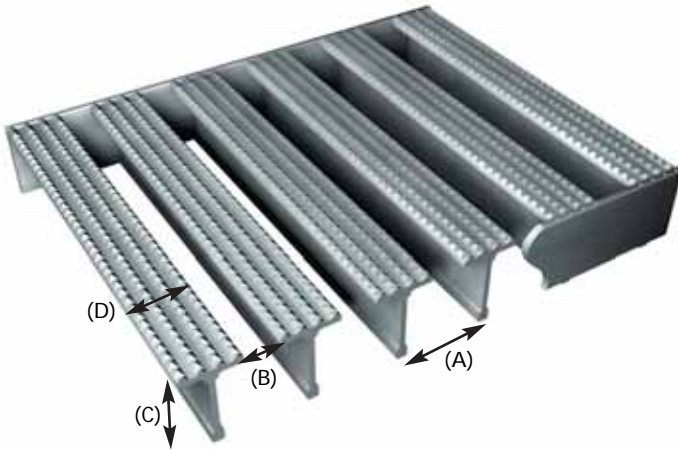

Stanweld	
Dimensions	
A	= 55.5mm centres
B	= 23.8mm opening
C	= 31.8mm depth
D	= 31.8mm width

max clear span for pedestrian loadings (mm)	def (mm)	L.B.B. size (mm)	Stanweld														Self Colour Weights per square metre (kgs)	Binding Bar Weight (based on 2 x 1m) (kgs)
			clear span (mm)															
				300	450	600	750	900	1050	1200	1350	1500	1650	1800	1950	2100		
a. 2226	10.00	31.8 T bar	kN/m ²	354.82	157.70	88.70	56.77	39.42	28.96	21.30	14.96	10.91	8.19	6.31	4.96	3.79	35.8	2.36
b. 1945	9.73		D (mm)	0.39	0.88	1.56	2.44	3.51	4.78	6.00	6.75	7.50	8.25	9.00	9.75	10.00		
c. 1699	8.50																	



Safe uniformly distributed loads (U.D.L.) in kilonewtons per square metre on simply supported panels with deflections (θ) in mm. Based on a working stress of 180 N/mm². Loads shown in the white area have been reduced to keep the deflections within 1/200th of the clear span or 10mm whichever is the lesser.

- a** – Light Duty 3 kN/m² described as access limited to one person only
- b** – General Duty 5 kN/m² described as regular two way pedestrian traffic
- c** – Heavy Duty 7.5 kN/m² described as high density pedestrian traffic

Load Table Designs allow for a 1kN load over a 300mm x 300mm area in accordance with BS 4592-0:2006

frictional fixings

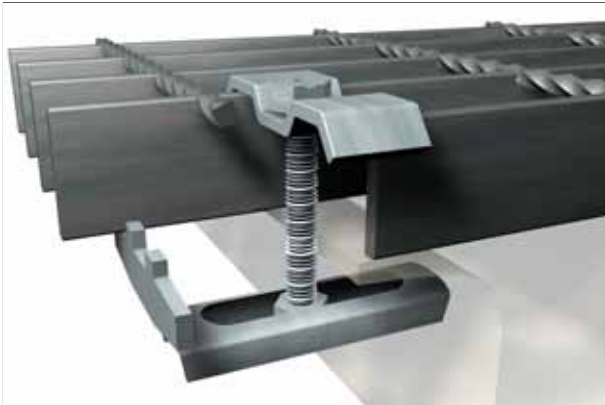

Frictional fixing clips are the most common method for fixing open grid flooring. The fixing assembly consists of a universal bottom clip (Type 5), M8 hex nut, bolt and a top clip.

The top clip is interchangeable and should be selected to suit each particular flooring. Below is a selection of our main top clips.

Note: Frictional fixings are supplied as a complete assembly unless otherwise requested.



▣ Saddle Clip

Safegrid

Safegrate

Safelock



▣ Type 5



▣ SG1 Clip

Safety Grating

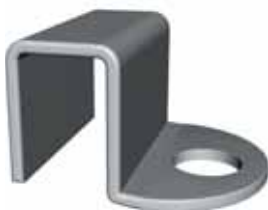

▣ Diamond Clip

Safetread



▣ Universal Deep Saddle Clip

Safegrid

Safegrate

Safelock



▣ Narrow Clip

Safegrid

Safegrate



▣ Panel Joining Clip

Specifications can often require that flooring panels are joined together to reduce deflection between adjacent panels. The Lionweld Kennedy joining clip has a slotted hole at both ends of the bottom clip, it is then secured using two M8 nuts, bolts and top clips of choice.

positive fixings

Positive fixings are used to secure the open grid flooring by bolting or firing through the steel support.

This method is generally used when the steel structure is subject to excessive vibrations.

Fixing Pad

35mm x 5mm pad welded to the flooring with a 10mm hole to allow the grating to be fixed directly to the supporting structure.



Deep Saddle with a self tapping bolt

A deep saddle clip is supplied to suit the depth of grating. A self tapping bolt is then used to secure the grating to the steel support.



clip-ons

To increase safety on open grid flooring and stairtreads, Lionweld Kennedy have devised a system of simple clip-on bars. These clip to the top of the steel flooring bars and provide an instant anti-slip surface - no drilling, bolting or welding required.

Clip-ons are also used to create a visual path along the open grid flooring for emergency escape routes. Clip-ons are usually supplied in orange for 5mm load bearing bars and red for 3mm load bearing bars.

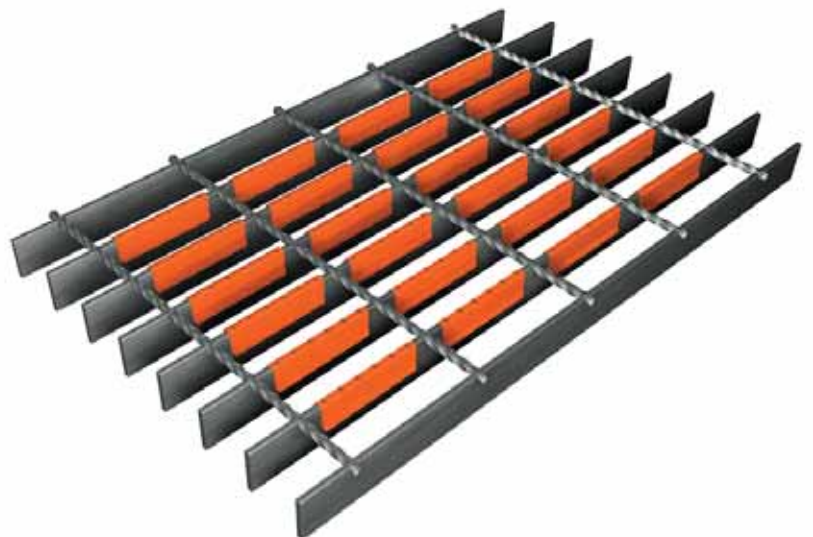
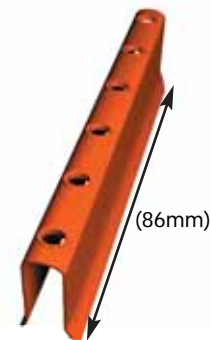

stairtreads

Lionweld Kennedy Stairtreads are constructed using an open steel grating from the flooring range.

Stairtreads are normally supplied with welded integral end plates, which are drilled to allow for bolting to stair stringers.

Stairtreads are supplied complete with full width nosing bar / sight bar to their leading edge.

Stairtreads		
Type	Designation	Nosing Type
Safegrid / Safety Grating rectangular pattern	RGL	Liongrip
Safetread / diamond pattern	DL	Liongrip
Floor Plate	CL	Liongrip
Safelock rectangular pattern	SLL	Liongrip
Stanweld	SC	Convex



Liongrip



Convex (stanweld only)



stairtreads

Standard Drilled End Plate

Stairtreads are fitted with drilled end plates to allow them to be bolted to the supporting stringer. The drilled hole positions have been standardised across the whole range of treads, however alternative drillings are available on request.

The end plate drilling consists of one fixed and one slotted hole to allow flexibility during installation.

The below sketch shows the standard end plate details.

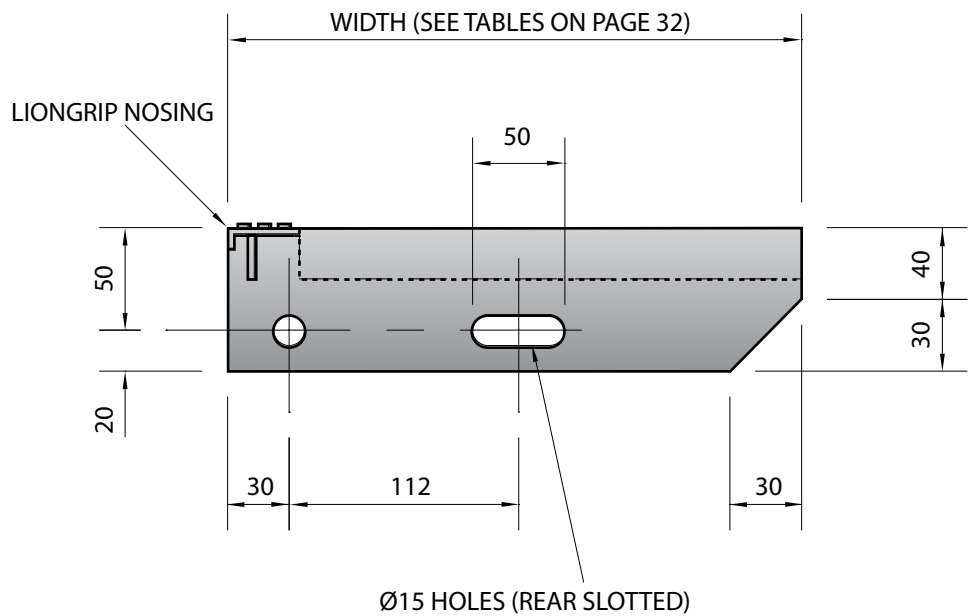
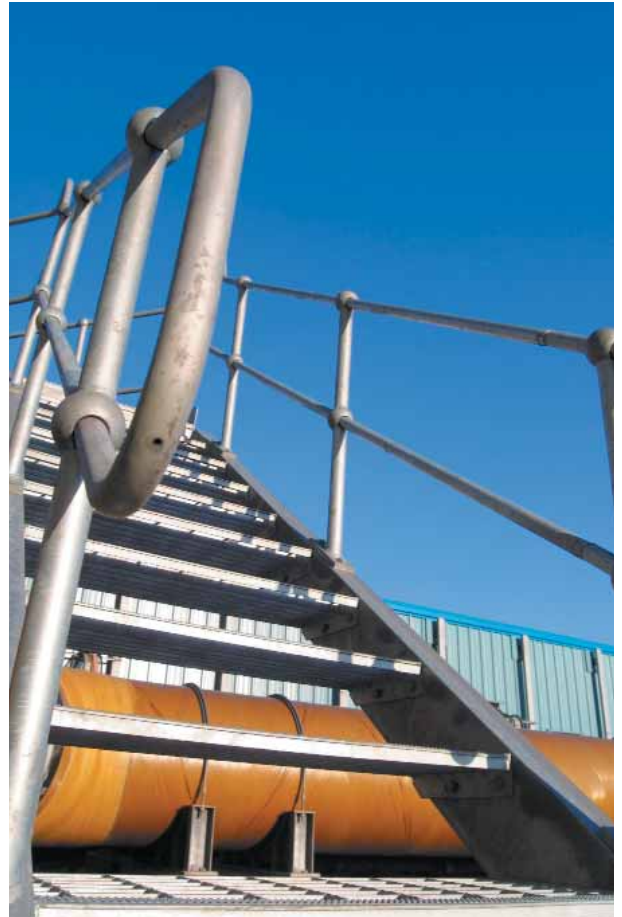
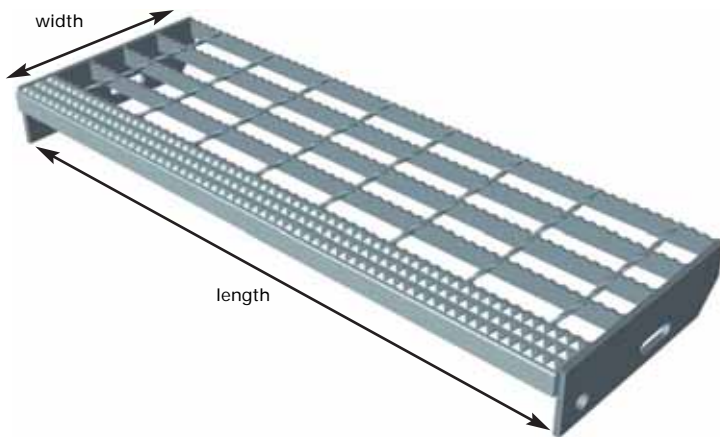

NOTE:

- Tread depth of 40mm and above have 80mm deep end plates with drillings 60mm down from the top of the tread.
- All end plates are 5mm thick.

standard tread widths

Standard tread widths are determined by the flooring pitch and are manufactured to the nearest bearing bar. If your application calls for an alternative width, this can be manufactured to suit however upsizing to the next standard size is usually acceptable as this will simply create a slight over-hang at the back of the stringer.

Safegrid Safety Grating Safelock Treads		
Pitch Size	Widths (5mm bars)	Widths (3mm bars)
41mm	206	204
	247	245
	288	288
	329	327
30mm	222	220
	252	250
	282	280
	312	310

Safetread Treads		
Pitch Size	Widths (5mm bars)	Widths (3mm bars)
40mm	200	n/a
	240	n/a
	280	n/a
	320	n/a
38mm	n/a	190
	n/a	228
	n/a	266
	n/a	304

Stanweld Treads	
Pitch Size	Widths (mm)
MS 55.5mm	93
	149
	204
	260
	315

Floorplate (8 OP) Treads	
Pitch Size	Widths (mm)
N/A	206
	247
	288
	329

maximum recommended tread lengths

Treads with a length less than 1200mm are designed to allow for a 1.5kN load distributed over a 100mm x 100mm area applied to the middle, front edge of the tread. Tread lengths greater than 1200mm allow for a 1.5kN load distributed over two areas of 100mm x 100mm.

Deflection of the tread should not exceed 1/300th of the length or 6mm, which ever is the lesser.

Stanweld SC (Convex Nosing)	
Pitch	Maximum Tread Lengths
MS (Medium Profile with 23.8mm opening)	1068

Floor Plate CL (Liongrip Nosing)	
Description	Maximum Tread Lengths
Liongrip nosing with 35 x 5 bar	1199

Safegrid / Safety Grating RGL (Liongrip Nosing)		
Load Bearing Bar Cross Centres	Maximum Tread Lengths	
	41mm pitch	30mm pitch
25 x 3	767	846
30 x 3	880	998
35 x 3	1017	1177
40 x 3	1175	1199
20 x 5	742	812
25 x 5	871	986
30 x 5	1034	1199
35 x 5	1199	1199
40 x 5	1199	1199
50 x 5	1305	1511

Safetread DL (Liongrip Nosing)		
Load Bearing Bar Cross Centres	Maximum Tread Lengths	
	40mm pitch	38mm pitch
25 x 3	n/a	793
30 x 3	n/a	887
35 x 3	n/a	1029
40 x 3	n/a	1199
20 x 5	759	n/a
25 x 5	900	n/a
30 x 5	1076	n/a
35 x 5	1199	n/a
40 x 5	1199	n/a
50 x 5	1199	n/a

Safelock SLL (Liongrip Nosing)		
Load Bearing Bar Cross Centres	Maximum Tread Lengths	
	41mm pitch	30mm pitch
25 x 3	627	651
30 x 3	688	737
35 x 3	777	860
40 x 3	893	1015
20 x 5	603	616
25 x 5	658	696
30 x 5	753	828
35 x 5	886	1006
40 x 5	1052	1199
50 x 5	1199	1211

saferail

Saferail comprises of a series of vertical solid or tubular stanchions and horizontal runs of tube to form a secure handrail system.

Stanchions

Stanchions are upright solid forged or tubular posts allowing the horizontal rail to be passed through. Stanchions come with various base plate options and are grub screwed to allow the rail to be secured into position.

Saferail can be specified using one of the following three systems:

Modular

Standard sections of handrail, available in various shapes and sizes to allow simple handrail systems to be pieced together.

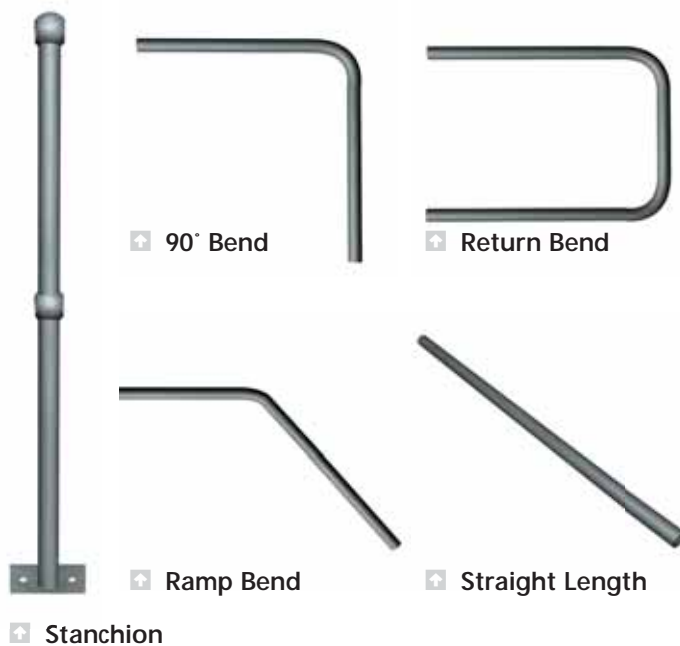

Fabricated

For more complicated handrail systems, Lionweld Kennedy offer a full fabrication service. Manufactured and piece marked to the customers requirements, handrail can be made to suit most applications.

Barrier Rail

Barrier Rail is supplied as a fully welded frame fabricated to suit client specifications. This system is predominately used in offshore installations.



solid stanchions

Solid Stanchions

Solid Forged stanchions are generally used in heavy duty or corrosive environments. With exception of the base plate, solid forged stanchions are manufactured as a complete unit without the need for welded joints.

This method of manufacture gives a high build quality and reduces the risk of moisture traps that can be associated with welded joints.

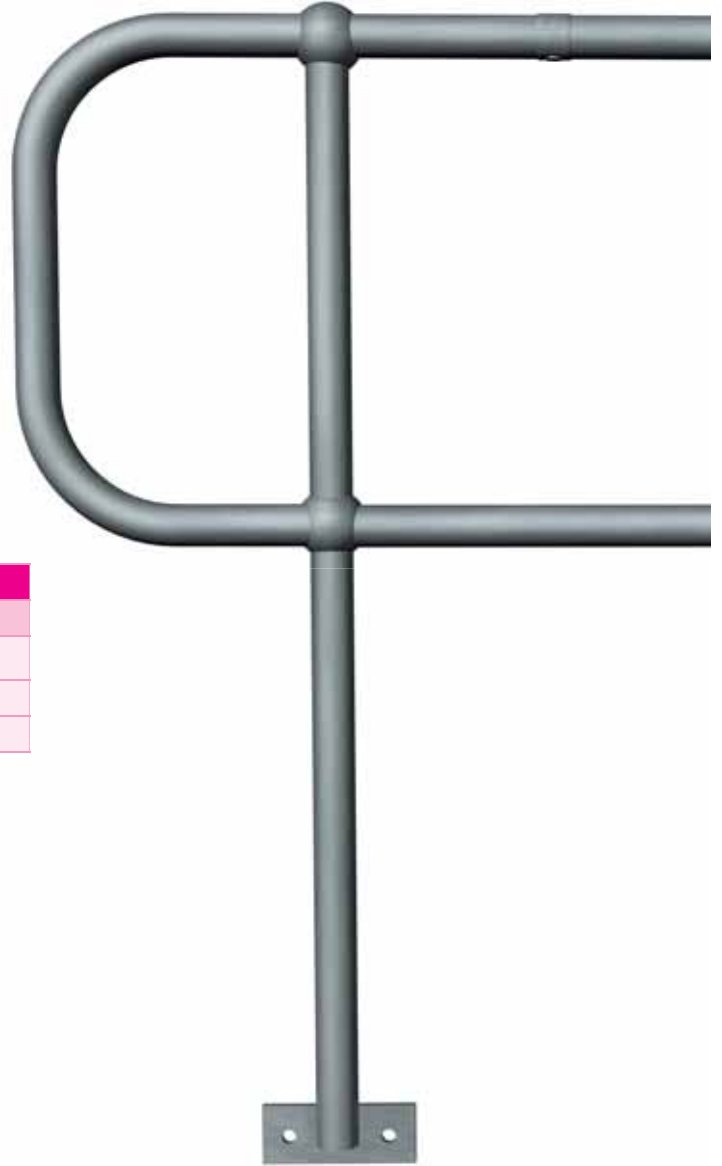

Solid Sizes

Shank Size	Ball Size	Rail Size
32mm	63mm	33.7mm o/d (25NB)
38mm	72mm	33.7mm o/d (25NB) or 42.4mm o/d (32NB)
45mm	80mm	42.4mm o/d (32NB)

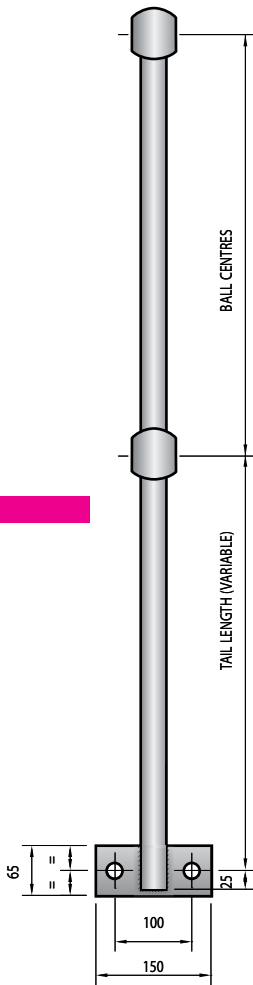

Ball Centres available:

- 450mm (Typically for stairs)
- 500mm,
- 533mm,
- 550mm

Type A

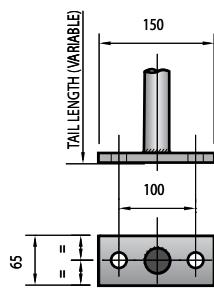

Type D

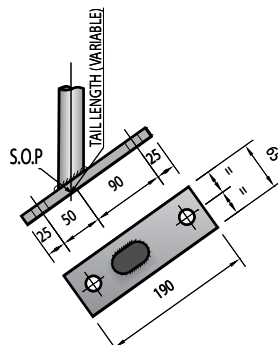

Type NX

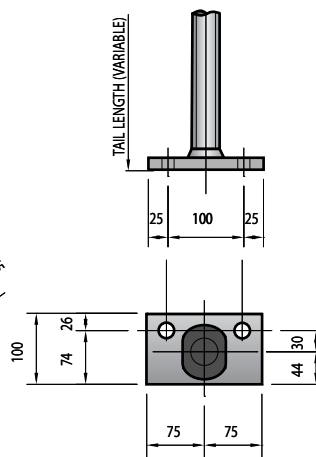

Type GX

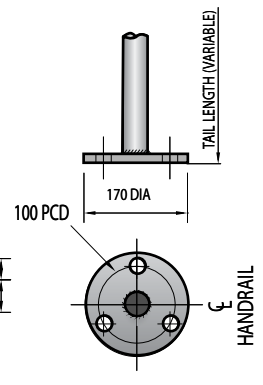

Type G

MEDIUM DUTY

HEAVY DUTY

tubular stanchions

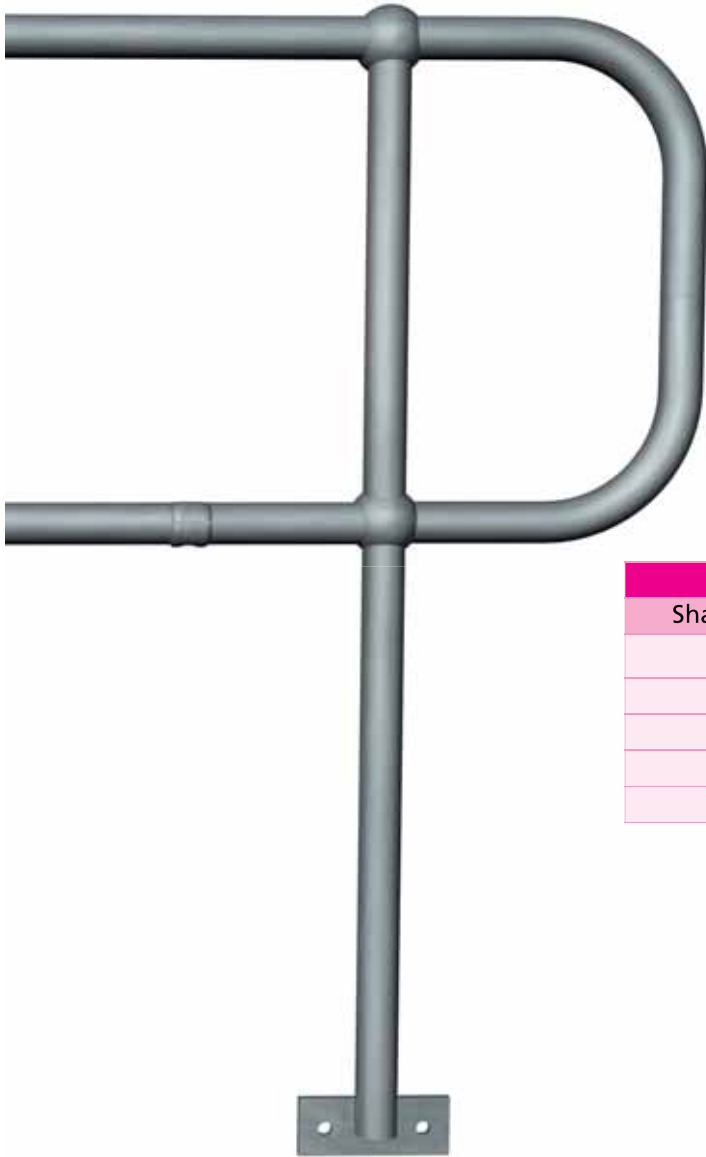

Tubular Stanchions

Tubular stanchions have similar load bearing capabilities as solid stanchions but are a much lighter and cost effective system.

Tubular stanchions are a welded construction and therefore not recommended in highly corrosive conditions.

Tubular Sizes		
Shank Size	Ball Size	Rail Size
25NB	64mm	33.7mm o/d (25NB)
32NB	64mm	33.7mm o/d (25NB)
32NB	75mm	33.7mm o/d (25NB) or 42.4mm o/d (32NB)
40NB	75mm	42.4mm o/d (32NB)
40NB	90mm	48.3mm o/d (40NB)

solid and tubular base plate options

Notes:

- For medium duty loadings (0.36kN/m) base plates are 12mm thick as standard.
- For heavy duty loadings (0.74kN/m) base plates are 15mm thick as standard.
- All drilled holes are 18mm diameter as standard.

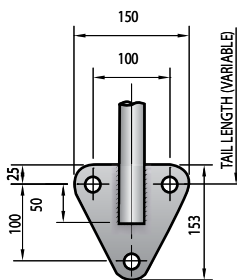

Type F

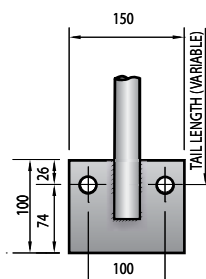

Type FX

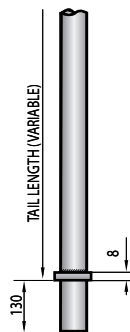

Type E
for use with H & J

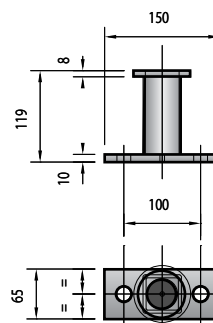

Type J

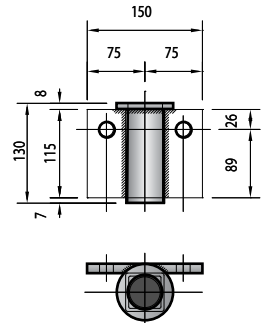

Type H

saferail load tables

The design load is the uniformly distributed load (UDL) applied horizontally to a handrail system at the design level.

The level considered for the design of handrail stanchions for platforms is 1100mm above the walking level and 900mm high on stairs.

Maximum Centres of Stanchions fixed to Steelwork

Item	Size	Material Grade	0.36kN/m (Medium Duty)			0.74kN/m (Heavy Duty)		
			Type D (Flat Base) 1100mm high	Type A (Side Palm) 1200mm high	Base Plates Thk	Type GX (Flat Base) 1100mm high	Type FX (Side Palm) 1200mm high	Base Plates Thk
Tubular Std	33.7 o/d x 3.0 thk (25NB)	S355	1040	820	12	500	375	15
Tubular Std	42.4 o/d x 3.0 thk (32NB)	S355	1560	1360	12	950	800	15
Tubular Std	48.3 o/d x 3.0 thk (40NB)	S355	1975	1825	12	1275	1150	15
Solid Std	32 dia solid	S275	1400	1180	12	700	575	15
Solid Std	38 dia solid	S275	1950	1800	12	1150	1050	15
Solid Std	45 dia solid	S275	2225	2125	12	1575	1450	15

All loading calculations are based on 33.7 o/d x 3.2mm thick handrail

handrail connectors

Expanding Connectors

Expanding connectors are used for joining:- 25mm nominal bore (33.7mm OD), 32mm nominal bore (42.4mm OD), 40mm nominal bore (48.4mm OD) tubular handrailing.

The connectors are simply pushed into the tube and secured by tightening the grub screw with an allen key. This type of connection is generally used for 3.2mm thick handrail.



Expanding Connector

Dowel Connectors

Each section of handrail tube should be drilled and tapped on site to enable an M8 grub screw to be located between the groove of the connector and be secured into position. This type of connection is generally used for 4mm thick handrail.



Dowel Connector



Wall Pad

Dimpled Connectors

Dimpled connectors are used to obtain an extremely quick joint, simply push the connectors into one of the tubes, align the arrow on the crimping tool and then squeeze the handles of the tool together. Dimpled connectors are only suitable for 25nb (33.7mm OD) tubular handrailing.

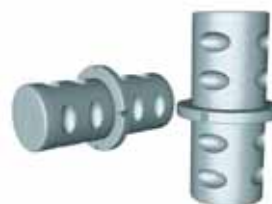

Dimpled Straight Crimp



Dimpled 90° Crimp

installation guidelines

Handrail Joints - Recommended to be positioned no more than 150mm away from the centre-line of the handrail stanchion.

Handrail Stanchions - To be positioned at no more than the maximum recommended pitch measured along the line of the handrail. One stanchion to be positioned no more than 300mm from a corner.

Return Bends - The stanchion is to be positioned no more than 300mm away from the bend in rails measured along the line of the rails.

On Stairs - A handrail stanchion is to be positioned at least 300mm from the work point at the bottom of a flight where rails continue from either a platform or a previous flight.

Grub screws - M8 grub screws are supplied as standard to secure the horizontal rail to the stanchion, providing improved stability.

gates and ladders

Lionweld Kennedy manufacture a range of tubular self-closing gates to compliment their handrail systems. Gates can be fully fabricated to suit your size and application.

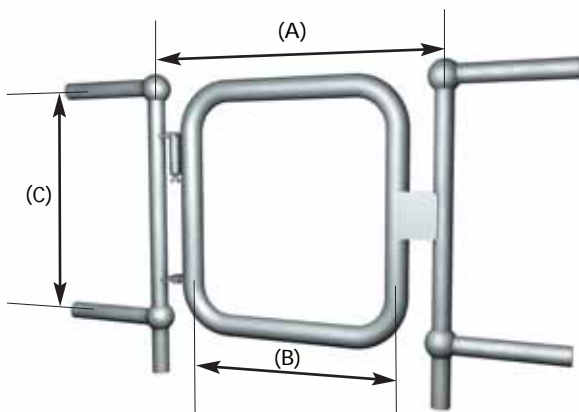

The following information is required to determine the size of the gate.

Gate Dimensions	
A	___ (mm)
B	___ (mm)
C	___ (mm)
Tube Size	25NB, 32NB, 40NB

Where verticle access is required, Lionweld Kennedy offer a range of cat ladders complete with safety cage.



toe plate fittings

Toe plate

A flat bar is used to form a barrier to prevent objects falling off the edge of the walkway. Toe plate can be welded to the flooring or fixed to the handrail stanchions using a U bolt or the Kickklamp system.

Fittings

Kickklamp brackets are a revolutionary system for fixing kick flat / toe plate to handrail standards. The basic principle involves gripping the toe plate with steel 'forked fingers' and fixing to the stanchion with a single grub screw.



Side Palm Fixing System

Alternate the KickKlamps (K25 / K40), fixing them to the top and bottom of the toe plate. On shorter runs, for extra security, use two kickklamps per stanchion, one on the top and one on the bottom of the toe plate.



K25 - to suit 25NB
K40 to suit 32NB - 40NB

Flat Base Fixing System

Fix KickKlamps to every stanchion on top of the toe plate and clamp down against the base plate of the stanchion.



KCB 1
Internal Corner



KCB 2
External Corner

Toe Plate Connectors

To accompany the KickKlamps, corner brackets (KCB1 / KCB2) and straight connectors (KCB3) can be used to join the lengths of toe plate as required.



KCB 3
Straight Connector

distribution

Lionweld Kennedy have a vast network of distributors operating across the UK and the rest of the world servicing the flooring and handrailing industry. Lionweld Kennedy's reputation for quality, service and practical solutions is recognized across the globe and are committed to expanding their network to create opportunities for distributors and their customers alike.

To enquire about becoming a distributor please contact the Lionweld Kennedy sales team.



industry sectors

Our product applications include:



Chemical & Process



Water & Waste Treatment



Rail & Transport



Offshore & Marine



Power Generation



Commercial